

Comments to Touchstone 2.0 proposals for MM support

Vladimir Dmitriev-Zdorov, Mentor Graphics Corporation

Support for mixed mode parameters is a toughest thing for users. Mess up in terminology adds to the pain. This is not about syntax only. There are some basics behind definitions that must be clearly understood when creating and using such parameters. A white paper is needed to define what can and what cannot be supported.

1. Terminals and ports

The model has T terminals and P ports. The terminal could be thought as the subcircuit's external node. The set of voltages and currents we use is defined by ports. Each port is created by pair of terminals. For every port, we can define port voltage, e.g. V_I and port current I_I . Note, that "return" port current I_I should always be equal I_I . Later we'll refer this as a condition of 'regularity'. In most cases, this return current is just 'assumed'.

The number of ports determines the number of external variables constituting voltage current vector (for Y/Z parameters) or incident/reflected wave vector for S-parameters. The number of ports also defines the size of the matrix, either S, Y or Z, that is P x P.

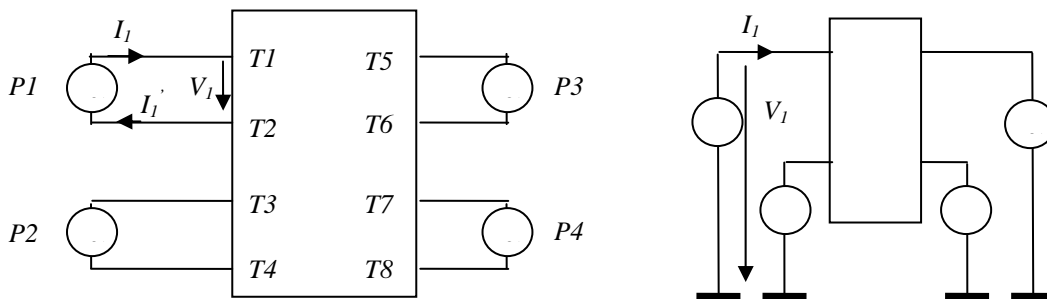

Fig.1

The Figure 1 exemplifies two cases. First, 8-terminal 4-port model. Second, 5-terminal 4-port model (here, one terminal is a common reference).

2. Ports with common or individual reference. 'Fully defined' or 'under-defined' models

In the first example above, each port voltage is measured with respect to its own 'reference' terminal. Same can be said about incident/reflected wave in case of S-parameters. The excitation to each port is applied in the same way. In the second case, all ports have the same common reference. All measurements 'across' are made relative to this reference.

For a given number of terminals, T , maximum $T-1$ independent voltages and $T-1$ number of independent currents can be defined. In case 2, with 5 terminals and 4 ports, we have the largest possible number of independent variables and also relations between them. The case $P=T-1$ produces ‘fully defined’ model. With its $P \times P$ parameter matrix, we can use this subcircuit in any configuration, with no limitation on the topology for external circuitry.

In case 1, we create 4×4 matrix to describe 8-terminal subcircuit, hence, it is not ‘fully’ defined. This case exemplifies the largest uncertainty: $P = T/2$.

‘Fully defined’ are only models with all ports having common reference.

Between two extremes (no common reference and a single common reference) there could be intermediate cases when one group of ports has its own common reference, while other group(s) have another reference.

4. Condition of ‘regularity’

The 4-port 8-terminal model on the left of Fig.1 is not ‘fully defined’, hence, not all configurations are allowed when we include this model into the design. Only those are allowed, for which we ensure that $I'_n \equiv I_n$, i.e. condition of regularity satisfied for all ports.

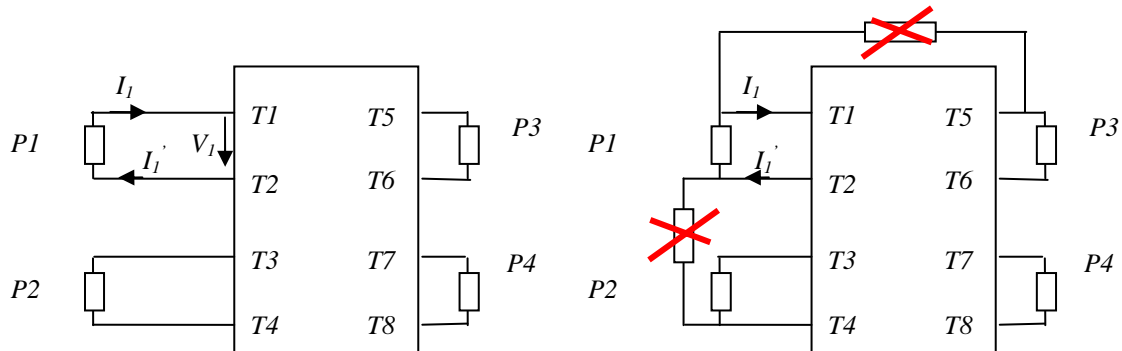

Fig.2 Legal and illegal model usage. The crossed are connections that violate regularity for ports 1 and 2, and ports 1 and 3.

If the model parameters were measured/created with certain port selection, the model can only be used in such configuration where regularity is satisfied for all defined ports. That is, the way the model is created must be consistent with the way it is used.

Note, that ‘fully defined’ model, with $P=T-1$, and common reference, always satisfies ‘regularity’.

5. Differential/common mode components can be created from a pair of ‘standard mode’ ports having the same reference terminal and identical normalizing impedance

This requirement about common reference terminal follows from regularity.

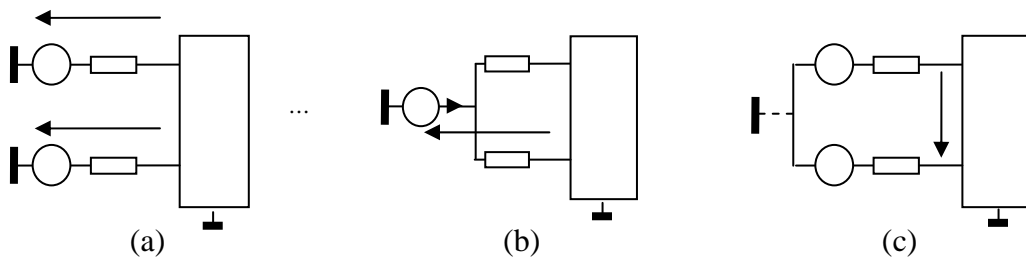

Fig.3 Two ports with common reference produce common and differential mode

As we see from Fig.3, if two ports have common reference (a), and the externally applied voltages are the same, then two sources can be combined into one common mode source. If the ports have similar input characteristics and the reference impedances are same, then the port voltages also become identical common mode voltages (b). As we see, the reference resistances become parallel for common mode and therefore the equivalent resistance for the common mode halves. If the voltages applied in (a) are equal but opposite, the input properties of the ports are similar and reference impedances are same, in Fig.3 (c) the current circulates in the loop and does not go into the reference terminal. Here we get differential mode and the reference impedance in the current loop doubles. If the input properties of ports are not the same, the port voltages in (b) are not exactly the same because there is a conversion from common to differential mode. Similarly, in (c) the fraction of the current leaves the loop and goes into reference terminal thus creating common mode component from differential input.

Note, that if the originating ports had individual reference terminals, the connections shown in Fig.3 (b) and (c) are not possible. In [4], pages 4-5 the ports are shown as having individual reference terminals, although they should have common.

Another conclusion: reference impedances of the pair of ‘standard mode’ ports must be the same to create the differential and common mode pair. That is, if the originating standard ports have different normalizing impedance, re-normalization should be done first, to make them equal and only after that mixed mode parameters can be defined. Hence, it is logical to require that under option line (#) or [Reference] keyword we define the reference impedances that are for the originating “standard” mode only. In case or [Reference], they should be equal for port pairs participating in producing mixed mode parameters.

6. Two port variables can create a pair containing of differential and common mode variables (i.e. mixed mode). Each port cannot be involved into more than one pair of ports that create differential/common mode

Let vector $\begin{bmatrix} X_1 \\ X_2 \\ X_3 \\ X_4 \end{bmatrix}$ describe port variables of a certain single type (voltages, currents,

incident or reflected waves) for 4-port model. If ports 1 and 2 have common reference terminal, the ‘standard’ mode variables for ports 1 and 2 can be replaced by the pair of similar type (voltage, current, etc.) differential/common variables, originating from this

pair of ports. Vector is replaced with another vector: $\begin{bmatrix} D_{1,2} \\ C_{1,2} \\ X_3 \\ X_4 \end{bmatrix}$. Total number of variables

remains the same. The low indexes indicate the ports of origination that are ports 1 and 2. This denotation is consistent with [1]. There, the common and differential mode variables bear indexes showing their originating standard (sometimes called single-ended) ports.

Then, if the ports 3 and 4 also have common reference terminal, the variables can also be

transformed into $\begin{bmatrix} D_{1,2} \\ C_{1,2} \\ D_{3,4} \\ C_{3,4} \end{bmatrix}$. Note that the pair 1, 2 and pair 3, 4 not necessarily have to have

the same common reference terminal. It only has to be common within each pair.

If other requirements stated above are true, the following pair mapping should be allowed, as shown in (a) and (b) in Fig.4 below. The mapping (c) should not be allowed since port 2 becomes involved into two STD to MM transformations.

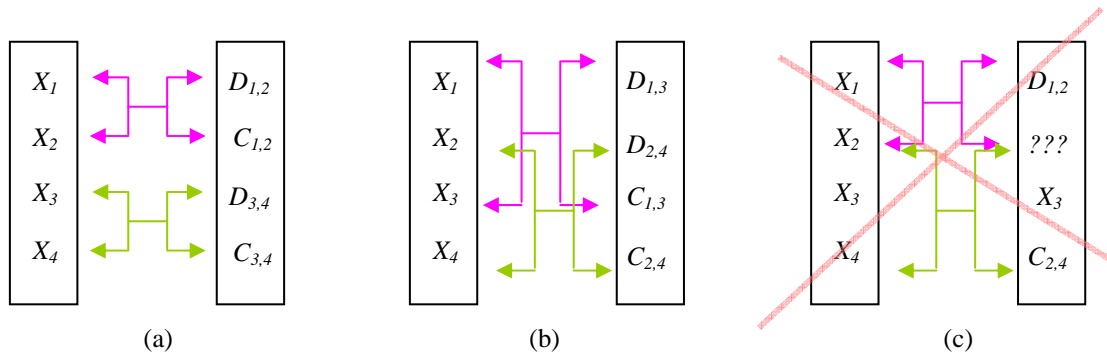

Fig.4. Two legal pair mappings (a), (b) and illegal (c).

7. Indexing variables and matrix components

Following the idea of [1], for each mixed mode variable we need to retain indexes showing the originating standard mode ports. Since each matrix component relates two

variables (one input, e.g. incident wave to one output, then reflected wave), it should have two sets of indexes from both variables.

Example:

$a_{D1,2}$ - incident wave, differential component originating from port 1 and 2.

$b_{C5,8}$ - reflected, common mode, originating from ports 5 and 8.

$S_{C5,8_D6,7}$ - matrix component that relates: $b_{C5,8} = S_{C5,8_D6,7} a_{D6,7}$

$S_{C5,8_X3}$ - matrix component that relates: $b_{C5,8} = S_{C5,8_X3} a_3$. Here, the input is a standard mode incident wave at port 3, the output is reflected common mode originated from ports 5 and 8.

Fortunately, as will be shown in the next section, we don't need to define the meanings of the matrix components in the touchstone file, as proposed in [5]. Only variable types in vector should be defined. Otherwise, I cannot think of what would happen if we decided to define mixed mode data for 200+ port S-parameter port (that we actually simulated some time ago, but in standard mode). Can we allow defining 50,000 matrix components then?

8. Defining types and ordering of port variables

What do standard mode S-parameters define? They define the relation between the incident and reflected vector, where the vector components on left and right are associated with *identically ordered* set of ports.

For example, the relation $\begin{bmatrix} b_1 \\ b_2 \\ b_3 \\ b_4 \end{bmatrix} = [S_{std}] \begin{bmatrix} a_1 \\ a_2 \\ a_3 \\ a_4 \end{bmatrix}$ satisfies the definition of S-parameter matrix

but $\begin{bmatrix} b_1 \\ b_2 \\ b_3 \\ b_4 \end{bmatrix} = [S_{std}^*] \begin{bmatrix} a_3 \\ a_2 \\ a_1 \\ a_4 \end{bmatrix}$ does not, because the ordering in the vectors is different.

Naturally, we have to require the same from the mixed mode matrix, or matrix that related non-uniform sets of variables, containing both mixed mode and standard mode

types. For example, this could be: $\begin{bmatrix} b_{D1,2} \\ b_{D3,4} \\ b_{C1,2} \\ b_{C3,4} \end{bmatrix} = [S_{mm}] \begin{bmatrix} a_{D1,2} \\ a_{D3,4} \\ a_{C1,2} \\ a_{C3,4} \end{bmatrix}$, where as we see the indexes in

vectors match.

Once the ordering is the same on both sides of the relation, there is no more ambiguity in defining the meaning of the matrix components, too. This was also noted in [4].

From here it follows that we need to define the meaning of the vector variables only. The type, as to whether it is incident or reflected, should not be defined.

For example:

D1,2
D3,4
C1,2
C3,4
X5 ! standard mode, port 5
X6 ! standard mode, port 6

Something like this should be present in the touchstone file. I don't insist on the particular syntax, I do care about having the condensed yet sufficient info. Of course, commas could be replaced with underscores and so on.

Another question is whether we need to have this under comments. This could potentially cause problem if mistakenly the come patterns in the 'regular' comments will trigger the mess. What about using a keyword for the section defining the port type/ordering?

9. Mapping sides A and B to port list

The issue is raised by Walter. Indeed, even for 4 port model we often do not know if the mixed mode parameters pair ports 1-2 and 3-4, or 1-3 and 2-4. With the proposed notation, this problem should be eliminated at least partially. For example, when we see D1,2 and C3,4 it means that the ports (1, 2), (3, 4) - in standard, "single ended" notation - make pairs. Hence, the ports 1, 2 are on one side and 3,4 are on the opposite side. Further details – if for example we care about flipping the model horizontally, or if we have more than two pair of ports - can be provided additionally in comments. In general, if we need to describe sides, we need first to define what the side means.

The 'side' issue may also exist if applied to standard mode. Here, we do not have indexes showing paired ports. Do we need it? Technically, the port pairs as a rule can be easily detected by analyzing the matrix values, e.g. S12/S34 versus S13 and S34. If any, what about defining top/bottom as well? If we decide to do this, then only for 4-ports that can represent differential channel.

10. Transforming matrices and non S-type parameters

Transformation for matrices, as well as for variables are given in some well recognized sources, e.g. [1-3]. We need to follow them when interpreting the data.

The conversion that links standard and mixed mode S-parameter matrix could be one from [3, (5-7)] or in [4].

It should be noted however that the matrix transformations defined there are for S-parameters only. The conversion between standard and mixed mode Y and Z parameters, consistent with definition of the common/differential mode voltage and current, as given in [1, (2)] and in [4], will require a different matrix.

Because of this, we can either (a) additionally provide explicit relations for Y/Z matrix transformations, too, or (b) do not support mixed mode non-S type parameters in order to avoid ambiguity in their interpretations.

Summary

- the user should be advised about the proper usage of the model, ensuring that the way it is included into design is consistent with the way it was created, and no regularity violations appear
 - the mixed mode components (diff/common) can only be created from port pairs with have common reference terminal and identical reference impedance
 - under [Reference] keyword we provide reference impedances for standard mode only
 - each port may participate only in one STD/MM conversion. The port pairs cannot 'overlap', as shown in Fig.4
 - indexes for mixed mode variables must retain the originating port numbers, that allows proper deciphering MM back into STD. Mapping "sides" is then simplified for MM parameters
 - the input and output vectors must have identical ordering and matching types of variables. This eliminates the need for defining the matrix components. Only mode types X/C/D and originating port pairs for C/D have to be defined
 - it is better to avoid putting this info into comments, maybe consider keyword definition instead
 - published MM/STD transformations cover S-parameter matrix only. Do we need to use them for Y/Z parameters? If yes, then appropriate transformation matrices should be provided
 - extended user manual is needed for touchstone format users, to explain possible caveats and provide mathematical relations. A good starting point could be publications [1-3]
-
1. A. Ferrero, M. Pirola. Generalized mixed mode S-parameters, IEEE Trans. on Microwave theory and Techniques, v.54, No.1, 2006.
 2. D. Bockelman, W. Eisenstadt. Pure mode network analyzer for on-wafer measurements of mixed mode S-parameters of differential circuits, IEEE Trans. on Microwave theory and Techniques, v.45, No.7, 1997.
 3. D. Bockelman, W. Eisenstadt. Combined differential and common mode scattering parameters: theory and simulation, IEEE Trans. on Microwave theory and Techniques, v.43, No.7, 1995.
 4. <http://www.eda.org/ibis/adhoc/interconnect/MixedModeSuggestions.pdf>
 5. <http://www.eda.org/ibis/adhoc/interconnect/S11.pdf>