

**IBIS Interconnect SPICE Subcircuits Specification
(IBIS-ISS)**

**Draft 0.5
July 27, 2010**

Statement of Changes

- Eliminated or reduced use of terms: token, netlist, command, you
- Defined or refined existing definitions for key concepts: statement, token, delimiter
- Added table of contents and imposed formatting (as defined under “Conventions”) to clarify relationships and hierarchies
- Added skeleton text for .subcircuit and .model definitions
- Standardized (for the most part) fonts, typefaces and other visual aspects of the document per “Conventions” section
- Removed portions of the document conventions that were unused
- Reordered some minor portions of the document to better accommodate the flow (more like a narrative)
- Clarified existing examples, particularly for comments and expressions
- Added parameter description text to support strings
- Clarified line continuation text

Contents

1. Statement of Changes	2
1. Overview	6
2. Goals and Scope.....	7
3. Conventions	10
4. Input Structure and Data Entry.....	11
1. Input File Guidelines	11
2. Statements and Tokens	11
3. Special Characters.....	13
4. First Character	16
5. Delimiters	17
6. Instance Names	17
7. Numbers.....	18
8. Parameters and Expressions	19
9. Node Name (or Node Identifier) Conventions	20
10. Element, Instance, and Subcircuit Naming Conventions.....	20
11. Line Continuations	21
5. Parameters	22
6. File Includes.....	31
7. Comments.....	32
8. Subcircuit Definitions.....	34
1. Subcircuit Scoping Rules	34
9. Subcircuit Definition Ending Statements	35
10. Elements	36
1. Subcircuits.....	36
2. Linear Resistor	36
3. Linear Capacitor.....	37
4. Voltage Shunt.....	37
5. Mutual Inductor	38
6. Linear Inductor	39
7. T-element (Ideal Transmission Line).....	39
8. W-element (Coupled Transmission Line)	41
Format 1: RLGC Model.....	42

Format 2: Frequency-Dependent Tabular Specification.....	44
9. S-element.....	50
10. E-element (Voltage-Controlled Voltage Source)	54
Linear	54
Laplace Transform	54
Pole-Zero Function.....	54
Foster Pole-Residue Form	55
11. F-element (Current-Controlled Current Source)	57
12. G-element (Voltage-Controlled Current Source)	58
Linear	58
Laplace Transform	58
Pole-Zero Function.....	58
Foster Pole-Residue Form	59
13. H-element (Current-Controlled Voltage Source)	61
14. Common Source Parameters.....	62
11. Best Practices	66

1. Overview

The IBIS Open Forum, in order to enable easier data exchange between users of signal/power integrity simulation and physical layout/routing software tools, is issuing a generic netlist format, to be called “IBIS Interconnect SPICE Subcircuits” (IBIS-ISS).

This format is similar in structure and major functions to the SPICE (Simulation Program with Integrated Circuit Emphasis) nodal syntax developed at the University of California at Berkeley and since implemented in various forms by individual software tool vendors. IBIS-ISS is the first industry-wide attempt to standardize SPICE subcircuit representation.

This version of IBIS-ISS is based on a subset of HSPICE ®, used with permission from Synopsys, Inc. HSPICE is a registered trademark of Synopsys, Inc.

2. Goals and Scope

The syntax of IBIS-ISS is intended to:

- describe interconnect structures (such as PCB traces, connectors, cables, etc.) electrically, for analysis in a signal integrity and/or power integrity context
- describe the arrangement or topology of interconnect structures, as they relate to each other and to active devices in a system

To these ends, IBIS-ISS includes support for:

- elementary circuit elements (resistors, capacitors, inductors)
- transmission line elements (lossless and lossy)
- frequency-domain network parameters (e.g., S-parameters)
- parameter/variable passing to elements and subcircuits
- dependent sources
- string-based node naming
- user-defined comments
- abstraction through modular, user-defined subcircuit definitions

IBIS-ISS does NOT include or cover:

- descriptions of complete netlists intended for input “as-is” to simulation tools
- model formats or “process cards” for active devices (e.g., diodes, transistors)
- independent sources
- controls or options for any simulation engine (e.g., precision, algorithm selection)
- simulation or analysis types (e.g., DC, transient)
- sweep or run control (e.g., Monte Carlo)
- geometrical descriptions for field solvers
- support for other kinds of data extraction/export (e.g., S-parameter generation)
- measurement, printing or probing
- encryption support

3.

•

•

4. Conventions

The following typographical conventions are used in IBIS-ISS. Note that these may be combined (e.g., Courier font in bold type).

Table 1: Document Conventions

Convention	Description
Courier	Indicates statement syntax.
<i>Italic</i>	Indicates a user-defined value, where a specific text string will replace the italics shown in an actual IBIS-ISS file (e.g., <i>Rxxxx</i> is a generic representation of a resistor element name, such as <i>Rname</i>).
Bold	Indicates verbatim text in syntax and examples
[]	Denotes optional tokens
...	Indicates that tokens of the same type may be added as appropriate to the element structure: pin1 pin2 ... pin
	Indicates a choice among defined alternatives, such as low medium high
+	Indicates a continuation of a statement across input lines. Note that continuation may only be used between tokens and shall not split any single token across lines.

5. Input Structure and Data Entry

This section describes the input file and structures for representing input data.

1. Input File Guidelines

An input file consists of a collection of statements describing a portion of a complete circuit. This input file is intended for inclusion in a larger netlist or description of a complete circuit, to be used by a simulation tool.

An input filename may be up to 1024 characters long. The input file shall be in ASCII format (insert IEEE or ANSI definition here). The input file shall not be in a binary, packed or compressed format.

2. Statements and Tokens

A statement in IBIS-ISS is a text string consisting of tokens and delimiters. An IBIS-ISS file may contain multiple statements (the number of statements is not limited by the IBIS-ISS definition, but may be limited by the computer architecture and/ or operating system used to process the file).

Any individual input statement may be up to 1024 characters long.

Statements in an input file may appear in any order.

Any valid string of characters between two token delimiters is a token.

For the purpose of this specification, statements are grouped into the following types:

- Element instances
- Parameter definitions
- File includes
- Subcircuit definitions
- Model definitions
- Comments
- Subcircuit ending statements

Subcircuit ending statements, subcircuit definitions, model definitions, parameter definitions and file includes all begin with the dot (.) character.

The specific syntax of the above statement types are described in the sections below.

- IBIS-ISS ignores differences between upper and lower case in input statements, except in quoted filenames.
- To continue a statement across multiple lines, the plus (+) sign shall be used as the first non-numeric, non-blank character of each continued line. The + sign shall be used only between tokens and token delimiters and never to split tokens.
- Tokens with extended length (such as paths and expressions) may span multiple lines using a single whitespace character followed by either a backslash (\) or a double backslash (\\) at the end of the line containing the token to be continued on the following line. Note that quoted strings may only be continued using the double backslash (\\) sequence.
- The following characters are reserved for special use and shall not be used as part of any parameter or node name:
 () = " '
- The following strings are reserved for special use and shall not be used as part of any parameter or node name in the associated element:

Element	Reserved Operators
Capacitor	POLY, TC, SENS
E/G-element	AND, DELAY, FOSTER, LAPLACE, NAND, NPWL, NOR, VCCS, OPAMP, OR, POLE, POLY, PWL, SPUR, TRANSFORMER, VCR, VCCAP, VCVS, FREQ, ZTRANS, VMRF, NOISE, NOISEFILE, MNAME, PHASE, SCALE, MAX, PAR
F/H-elements	POLY, PWL, AND, NAND, OR, NOR, VMRF, CCCS, C CVS, DELAY
Port element	SIN, PU, PWL, EXP, PULSE, PE, SFFM, AM, PAT, PL, HB, HBAC, DATA, AC, DC, LSAC, SNAC, PHOTO, NEUT, COS, VMRF, LFSR, PUL, HBLIN, R, BITSTREAM, PWLFILE, MOD, FILTER
Inductor	POLY, TC, SENS, RELUCTANCE, TRANSFORMER_NT, FILE
Resistor	POLY,TC,SENS

S-element	ZO, Z0, MNAME
T/U- element	IC
W-element	RLGCFILE, PRINTZO, RLGCMODEL, TABLEMODEL, FSMODEL, UMODEL, SMODEL

3. Special Characters

The following table lists the special characters that may be used as part of node names, element parameter names, and element instance names. For detailed discussion, see the appropriate sections in this chapter.

Note:

To avoid unexpected results or error messages, do not use the following mathematical characters in a parameter name in IBIS-ISS: * - + ^ and /.

Table 2: IBIS-ISS / Netlist Special Characters

Special Character*		Node Name	Instance Name**	Parameter Name**	Comments
~	tilde	Legal anywhere	Included only	Included only	n/a
!	exclamation point	Legal anywhere	Included only	Included only	n/a
@	at sign	Legal anywhere	Included only	Included only	n/a
#	pound sign	Legal anywhere	Included only	Included only	n/a
\$	dollar sign	Included only (avoid if after a number in node name)	Included only	Included only	In-line comment character

%	percent	Legal anywhere	Included only	Included only	n/a
^	caret	Legal anywhere	Included only	included only (avoid usage)	“To the power of”, i.e., 2 ⁵ , two raised to the fifth power
&	ampersand	Legal anywhere	Included only	Included only	n/a
*	asterisk	Included only (avoid using in node names)	Included only	included only (avoid using in parameter names)	Comment and wildcard character. Double asterisk (**) is “to the power of”.
()	parentheses	Illegal	Illegal	Illegal	Token delimiter
-	minus	Included only	Included only	Illegal	n/a
_	underscore	Legal anywhere	Included only	Included only	n/a
+	plus sign	Included only	Included only	Included only (avoid usage)	Continues previous line, except for quoted strings
=	equals	Illegal	Illegal	optional in .PARAM statements	Token delimiter
< >	less/more than	Legal anywhere	Included only	Included only	n/a

?	question mark	Legal anywhere	Included only	Included only	Wildcard character
/	forward slash	Legal anywhere	Included only	Illegal	n/a
{ }	curly braces	included only, converts to []	Included only	Included only	Engine shall auto-convert to square brackets ([])
[]	square brackets	Included only	Included only	Included only	n/a
\	backslash (requires a whitespace before to use as a continuation)	Included only	Included only	Illegal	Continuation character (preserves whitespace)
\\	double backslash	Included only	Illegal	Illegal	Continuation character for quoted strings (preserves whitespace)
	pipe	Legal anywhere	Included only	Included only	n/a
,	comma	Illegal	Illegal	Illegal	Token delimiter
.	period	Illegal	Included only	Included only	Statement identifier, (i.e., .PARAMETER, etc.).
:	colon	Included only	Included only	Included only	Delimiter for element attributes

;	semi-colon	Included only	Included only	Included only	n/a
" "	double-quotes	Illegal	Illegal	Illegal	Expression and filename delimiter
' '	single quotes	Illegal	Illegal	Illegal	Expression and filename delimiter
	Blank (whitespace)	Use before \ line (token) continuations	Illegal	Illegal	Token delimiter

*"Legal anywhere"=first character or any position in string

"Included only"=any position except first character

** cannot be the first character; element key letter only

4. First Character

The first character in every line specifies how IBIS-ISS interprets the remainder of the line.

Table 3: First Character Rules

If the First Character is...	Indicates
. (period)	Statement identifier (e.g., .PARAM)
c, C, e, E, f, F, g, G, h, H, , k, K, l, L, r, R, s, S, v, V, w, W	Element instantiation
* (asterisk)	Comment line
+ (plus)	Continues previous line

5. Delimiters

Delimiters separate tokens (strings) in the input file. Input token delimiters are: tab, blank, comma (,), equal sign (=), and parentheses ().

In addition, single (') or double quotes (") delimit tokens used as expressions and filenames.

6. Instance Names

The names of element instances begin with the element key letter, except for subcircuit instances, whose instance names begin with X. Instance names may be up to 1024 characters long.

Table 4 Element Identifiers

Key Letter (First Char)	Element	Example Line
C	Capacitor	Cbypass 1 0 10pf
E	Voltage-controlled voltage source	Ea 1 2 3 4 K
F	Current-controlled current source	Fsub n1 n2 vin 2.0
G	Voltage-controlled current source	G12 4 0 3 0 10
H	Current-controlled voltage source	H3 4 5 Vout 2.0
K	Linear mutual inductor (general form)	K1 L1 L2 1
L	Linear inductor	LX a b 1e-9
R	Resistor	R10 21 10 1000
S	S-parameter element	S1 nd1 nd2 s_model2
V	Voltage source	V1 8 0 DC=0

W	Transmission Line	W1 in1 0 out1 0 N=1 L=1
T	Transmission Line	Txxx in 0 out 0 Z0=50 TD=30n
X	Subcircuit instance	X1 2 4 17 31 MULTI WN=100 LN=5

7. Numbers

Numbers may be entered as integer, floating point, floating point with an integer exponent, or integer or floating point with one of the scale factors listed below.

Table 5: Scale Factors

Scale Factor	Prefix	Symbol	Multiplying Factor
T	tera	T	1e+12
G	giga	G	1e+9
MEG or X	mega	M	1e+6
K	kilo	k	1e+3
MIL	n/a	none	25.4e-6
M	milli	m	1e-3
U	micro	μ	1e-6
N	nano	n	1e-9
P	pico	p	1e-12

F	femto	f	1e-15
A	atto	a	1e-18

Note:

Scale factor A is not a scale factor in a character string that contains amps. For example, IBIS-ISS interprets the 20amps string as 20e-18mps (20^{-18} amps), but it correctly interprets 20amps as 20 amperes of current, not as 20e-18mps (20^{-18} amps).

- Numbers may use exponential format or engineering key letter format, but not both (1e-12 or 1p, but not 1e-6u).
- To designate exponents, use D or E.
- Trailing alphabetic characters are interpreted as units comments.
- Units comments are not checked.

8. Parameters and Expressions

- Parameter names shall begin with an alphabetic character. Subsequent characters in the parameter name shall each be either a digit, or one of these following characters:

! # \$ % [] _

- If multiple definitions are given for the same parameter, IBIS-ISS uses the last parameter definition even if that definition occurs later in the input than a reference to the parameter.
- A parameter shall be defined before that parameter is used in a definition for another parameter.

To delimit expressions, single quotes shall be used

Expressions cannot exceed 1024 characters.

- Parameters are used in two contexts.
 - Parameters in parameter definition statements are strings, defining names to be used as variables which are assigned specific values by the statement. These values may be numeric, strings defining an expression or equation, or strings matching parameters defined elsewhere.
 - Parameters may also appear in element instances, model definitions and subcircuit definitions. These parameters may be user-defined or may use names pre-defined by the syntax of the element.

- Parameter names are input tokens. Token delimiters shall precede and follow names.
- Parameter names may be up to 1024 characters long and are not case-sensitive.

9. Node Name (or Node Identifier) Conventions

Nodes are the points of connection between elements in the input netlist. Only alphanumeric strings shall be used to designate nodes. If entirely numeric, node numbers shall be between 1 and 9999999999999999 (1 to $1e16-1$). A node number of 0 is permitted but is interpreted as ground. Letters that follow a leading number in a node name are ignored; this means that node strings such as '3n5' and '3' shall be interpreted as referring to the same node.

When the node name begins with a letter or a valid special character, the node name may contain a maximum of 1024 characters.

To indicate the ground node, use either the number 0, the name GND, or !GND, or GROUND, GND!. Every node shall have at least two connections, except for transmission line nodes (unterminated transmission lines are permitted) and MOSFET substrate nodes (which have two internal connections).

10. Element, Instance, and Subcircuit Naming Conventions

Instances and subcircuits are elements and as such, follow the naming conventions for elements.

Element names begin with a letter designating the element type, followed by up to 1023 alphanumeric characters. Element type letters are R for resistor, C for capacitor and so on.

11. Line Continuations

Lines are continued in one of three ways, depending on how input is divided across the line:

- Statements are continued using the + character
- Tokens are continued using the \\ sequence
- Tokens may also be continued using whitespace followed by the \ character

To continue a statement across multiple lines, the plus (+) sign shall be used as the first non-numeric, non-blank character of each continued line. The + sign shall be used only between tokens and token delimiters and never to split tokens.

Here is an example of comments and line continuation in a netlist file:

```
*This shows continuation of a statement describing a resistor  
Rexample  
+ n3 n4 R=30
```

To continue a token with extended length (such as paths and expressions) but preserve readability, the token shall be split using a single whitespace character followed by a backslash (\) or a double backslash (\\) without leading whitespace at the end of the line containing the token to be continued on the following line.

```
* This shows continuation of a token in a statement, in this  
* case an expression, describing a resistor  
Rexample n3 n4 R='sin(30.12345 + 4.356789 - cos(32.67 - \\  
234))'
```

```
* This shows an identical continuation of a token in a  
* statement, in this case an expression, describing a resistor  
Rexample n3 n4 R='sin(30.12345 + 4.356789 - cos(32.67 - \  
234))'
```

6. Parameters

Parameters are similar to the variables used in most programming languages. Parameters hold values assigned when the circuit design is created or that are calculated based on circuit solution values. Parameters may store static values for a variety of quantities (resistance, source voltage, rise time, and so on). Parameters may also be alphabetic strings used with elements where string input is expected (for example, filenames or model names).

Using Parameters in Simulation (.PARAM)

Defining Parameters

Parameters may be defined using the methods shown below. Note that a .param statement without an assignment is not permitted.

Table 6: .PARAM Statement Syntax and Examples

Token	Description/Example
Simple Assignment	<code>.PARAM SimpleParam=1e-12</code>
Algebraic Definition	<code>.PARAM AlgebraicParam='SimpleParam*8.2'</code> .
User-defined Function	<code>.PARAM MyFunc(x,y)='SQRT((x*x)+(y*y))'</code>
String Assignment	<code>.PARAM StringParam=str('mystring')</code>
Subcircuit Definition	<code>.SUBCKT SubName ParamDefName=Value</code>
Subcircuit Instance	<code>Xxxx nodename1 ... nodenamen</code> <code>+ SubName</code> <code>+ ParamDefName = Value str('string')</code>
Predefined Analysis	<code>.PARAM f(a,b)=POW(a,2)+a*b g(d)=SQRT(d)</code> <code>+ h(e)=e*f(1,2)-g(3)</code>

Function	
----------	--

A parameter definition in IBIS-ISS always uses the last value found in the input netlist. The definitions below assign a value of 3 to the `DupParam` parameter.

```
.PARAM DupParam=1
...
.PARAM DupParam=3
```

IBIS-ISS assigns 3 as the value for all instances of `DupParam`, including instances that are earlier in the input than the `.PARAM DupParam=3` statement.

All parameter values in IBIS-ISS are IEEE double floating point numbers. The parameter resolution order is:

1. Resolve all literal assignments.
2. Resolve all expressions.
3. Resolve all function calls.

Table 7 shows the parameter passing order.

Table 7: Parameter Passing Order

.PARAM statement ()	.SUBCKT call (instance)
.SUBCKT call (instance)	.SUBCKT definition (symbol)
.SUBCKT definition (symbol)	.PARAM statement ()

Assigning Parameters

The following types of values may be assigned to parameters:

- Constant real number
- Algebraic expression of real values
- Predefined function
- Circuit value
- Model value
- Strings not for algebraic evaluation

To invoke the algebraic processor, the complex expression to be evaluated shall be enclosed in single quotes.

A simple expression consists of one parameter name. Simple expressions shall not be enclosed in single or double quotes.

The parameter keeps the assigned value, unless a later definition changes its value.

Inline Parameter Assignments

To define circuit values, using a direct algebraic evaluation:

```
r1 n1 0 R='1k/sqrt(HERTZ)' $ Resistance for frequency
```

Using Algebraic Expressions

In IBIS-ISS, an algebraic expression, with quoted strings, may replace any parameter.

Some uses of algebraic expressions are:

- Parameters:

```
.PARAM x='y+3'
```

- Algebra in elements:

```
R1 1 0 r='ABS(v(1)/i(m1))+10'
```

The continuation character for quoted parameter strings, in IBIS-ISS, is a double backslash (\\) (outside of quoted strings, the single backslash (\) is the continuation character).

Built-In Functions and Variables

In addition to simple arithmetic operations (+, -, *, /), the built-in functions and variables listed below may be used in IBIS-ISS expressions.

Table 8: IBIS-ISS Built-in Functions

IBIS-ISS Form	Function	Class	Description
sin(x)	sine	trig	Returns the sine of x (radians)
cos(x)	cosine	trig	Returns the cosine of x (radians)
tan(x)	tangent	trig	Returns the tangent of x (radians)
asin(x)	arc sine	trig	Returns the inverse sine of x (radians)
acos(x)	arc cosine	trig	Returns the inverse cosine of x (radians)
atan(x)	arc tangent	trig	Returns the inverse tangent of x (radians)
sinh(x)	hyperbolic sine	trig	Returns the hyperbolic sine of x (radians)
cosh(x)	hyperbolic cosine	trig	Returns the hyperbolic cosine of x (radians)
tanh(x)	hyperbolic tangent	trig	Returns the hyperbolic tangent of x (radians)
abs(x)	absolute value	math	Returns the absolute value of x: $ x $
sqrt(x)	square root	math	Returns the square root of the absolute value of x: $\text{sqrt}(-x)=-\text{sqrt}(x)$
pow(x,y)	absolute power	math	Returns the value of x raised to the integer part of y: $x^{(\text{integer part of } y)}$

pwr(x,y)	signed power	math	Returns the absolute value of x, raised to the y power, with the sign of x: (sign of x) x ^y
x**y	power		If x<0, returns the value of x raised to the integer part of y. If x=0, returns 0. If x>0, returns the value of x raised to the y power.
log(x)	natural logarithm	math	Returns the natural logarithm of the absolute value of x, with the sign of x: (sign of x)log(x)
log10(x)	base 10 logarithm	math	Returns the base 10 logarithm of the absolute value of x, with the sign of x: (sign of x)log ₁₀ (x)
exp(x)	exponential	math	Returns e, raised to the power x: e ^x
db(x)	decibels	math	Returns the base 10 logarithm of the absolute value of x, multiplied by 20, with the sign of x: (sign of x)20log ₁₀ (x)
int(x)	integer	math	Returns the integer portion of x. The fractional portion of the number is lost.
nint(x)	integer	math	Rounds x up or down, to the nearest integer.
sgn(x)	return sign	math	Returns -1 if x is less than 0. Returns 0 if x is equal to 0. Returns 1 if x is greater than 0
sign(x,y)	transfer sign	math	Returns the absolute value of x, with the sign of y: (sign of y) x

def(x)	parameter defined	control	Returns 1 if parameter x is defined. Returns 0 if parameter x is not defined.
min(x,y)	smaller of two args	control	Returns the numeric minimum of x and y
max(x,y)	larger of two args	control	Returns the numeric maximum of x and y
[cond] ?x : y	ternary operator		Returns x if <i>cond</i> is not zero. Otherwise, returns y. .param z='condition ? x:y'
<	relational operator (less than)		Returns 1 if the left operand is less than the right operand. Otherwise, returns 0. .para x=y<z (y less than z)
<=	relational operator (less than or equal)		Returns 1 if the left operand is less than or equal to the right operand. Otherwise, returns 0. .para x=y<=z (y less than or equal to z)
>	relational operator (greater than)		Returns 1 if the left operand is greater than the right operand. Otherwise, returns 0. .para x=y>z (y greater than z)
>=	relational operator (greater than or equal)		Returns 1 if the left operand is greater than or equal to the right operand. Otherwise, returns 0. .para x=y>=z (y greater than or equal to z)
==	equality		Returns 1 if the operands are equal. Otherwise, returns 0. .para x=y==z (y equal to z)

!=	inequality		Returns 1 if the operands are not equal. Otherwise, returns 0. .para x=y!=z (y not equal to z)
&&	Logical AND		Returns 1 if neither operand is zero. Otherwise, returns 0. .para x=y&&z (y AND z)
	Logical OR		Returns 1 if either or both operands are not zero. Returns 0 only if both operands are zero. .para x=y z (y OR z)

Table 12 *IBIS-ISS Special Variables*

IBIS-ISS Form	Function	Class	Description
time	current simulation time	control	Uses parameters to define the current simulation time, during transient analysis.
temper	current circuit temperature	control	Uses parameters to define the current simulation temperature, during transient/temperature analysis.
hertz	current simulation frequency	control	Uses parameters to define the frequency, during AC analysis.

String Parameters

Parameters may be defined and instantiated using strings, String parameters use special syntax as tokens such as single quotes ('), double quotes ("), or curly brackets ({}) do not work for string parameter definitions or usage.

When defining a parameter that is a character string, the token and delimiter combination `str('string')` shall be used to define the parameter, where *string* is the string to be used as the parameter value. When an instance of the parameter is used, the parameter name is called as `str(parameter_name)`.

IBIS-ISS supports string parameter definition and instantiation for the following netlist components:

- .PARAM statements
- .SUBCKT statements
- S-parameter FQMODEL in both the S-parameter instance and S-parameter model and the TSTONEFILE keyword in the S-element
- FILE and MODEL keywords
- W-element keywords RLGCFILE, RLGCMODEL, UMODEL, FSMODEL, TABLEMODEL, and SMODEL

String parameters may be used as arguments to all model name tokens.

Syntax

```
Rxxx n1 n2 [mname [str(mname)]] Rval [TC1 [TC2] [TC]] [SCALE=val]
+ [M=val] [AC=val] [DTEMP=val] [L=val] [W=val] [C=val]
+[NOISE = val]
```

Parameter Scoping and Passing

If parameters are used to define values in sub-circuits, fewer similar cells should be used, to provide enough functionality in the resulting library. Circuit parameters may be passed into hierarchical designs, and different values may be assigned to the same parameter within individual cells, when simulations are run.

A parameter is defined either by a .parameter statement (local to that subcircuit), or may be passed into a subcircuit, or may be defined on a .subckt definition line.

```
.param x=0
```

```
.subckt def
.param x=1
x1 1 2 abc x=2
.subckt abc 1 2 x=3
.param x=3
r1 1 2 R=x
.ends abc
.ends def
.end
```

7. File Includes

The include statement inserts another file's contents in the current file at evaluation.

Syntax

```
.INCLUDE `file_path file_name`  
.inc `file_path file_name`
```

Arguments

Argument	Description
<i>file_path</i>	<p>Path name of a file for computer operating systems that support tree-structured directories.</p> <p>An include file can contain nested .INCLUDE calls to itself or to another include file. If a relative path is used in a nested .INCLUDE call, the path starts from the directory of the parent .INCLUDE file, not from the current working directory. If the path starts from the current working directory, IBIS-ISS may also find the .INCLUDE file, but prints a warning.</p>
<i>file_name</i>	<p>Name of a file to include in the data file. The file path, plus the file name, may be up to 16 characters long. Any name valid under the computer's operating system may be used.</p>

Use this token to include another netlist in the current circuit description. The file path and file name shall be enclosed in single or double quotation marks.

```
.INCLUDE `~/myhome/subcircuits/diode_circuit`
```

8. Comments

Comments require an asterisk (*) as the first character in a line or a dollar sign (\$) directly in front of the comment anywhere on the line. For example:

```
* <comment_on_a_line_by_itself>
```

or

```
<IBIS-ISS statement> $ <comment following input>
```

Comment statements may appear anywhere in the circuit description. The dollar sign (\$) shall be used for comments that do *not* begin in the first character position on a line (for example, for comments that follow simulator input on the same line). If it is not the first nonblank character, then the dollar sign shall be preceded by either:

- Whitespace
- Comma (,)
- Valid numeric expression

The dollar sign may also be used within node or element names. For example:

```
* RF=1K GAIN SHOULD BE 100
$ CIRCUIT EXAMPLE
VIN 1 0 PL 0 0 5V 5NS $ 10v 50ns
R12 1 0 1MEG $ FEED BACK
.PARAM a=1w$comment a=1, w treated as a space and ignored
.PARAM a=1k$comment a=1e3, k is a scale factor
```

A dollar sign is the preferred way to indicate comments, because of the flexibility of its placement within the code.

9. Model Definitions (.MODEL Statements)

Model definitions are used to specify the electrical parameters for W-element and S-element instances. They can be considered a special form of subcircuit definition, in which the defined subcircuit is only available to W- and S-elements.

The specific syntax for W-element and S-element .MODEL definitions are detailed below, as part of the W-element and S-element portions of the IBIS-ISS specification. Note that .MODEL statements are hierarchically at the same level as element instances.

10. Subcircuit Definitions

Syntax

```
.subckt name n1 n2...  
statement  
statement  
statement  
...  
.ends
```

1. Subcircuit Scoping Rules

A .subckt or .model definition shall occur in the subcircuit in which the subcircuit or model is referenced, or in a calling subcircuit at any level above.

11. Subcircuit Definition Ending Statements

Subcircuit definitions shall end with the `.ends` token. See Subcircuit Definitions above for syntax and examples.

12. Elements

The sections below describe the individual circuit elements that may appear in an IBIS-ISS file.

1. Subcircuits

Reusable cells are the key to saving labor in any CAD system. To create and simulate a reusable circuit, construct it as a subcircuit. Use parameters to expand the utility of a subcircuit.

X<*subcircuit_name*> creates an instance of a subcircuit. . The subcircuit shall have already been defined elsewhere in the IBIS-ISS file using a .SUBCKT statement.

Syntax

```
Xxxxx n1 [n2 n3 ...] subnam  
[parnam = val] [M = val]
```

Argument	Definition
<i>X</i> < <i>subcircuit_name</i> >	Subcircuit element name. Shall begin with an X, followed by up to 15 alphanumeric characters.
<i>n1 ...</i>	Node names for external reference.
<i>subnam</i>	Subcircuit model reference name.
<i>Parnam</i>	A parameter name set to a value (val) for use only in the subcircuit. It overrides a parameter value in the subcircuit definition, but is overridden by a value set in a .PARAM statement.
<i>M</i>	Multiplier

2. Linear Resistor

A linear resistor is a basic electrical circuit element for impeding current flow.

Syntax

Rxxx node1 node2 [R =] value

The value of a linear resistor may be a constant, or an expression of parameters.

Token	Description
<i>Rxxx</i>	Name of a resistor
<i>node1</i> and <i>node2</i>	Names or numbers of the connecting nodes
<i>value</i>	resistance value, in ohms

3. Linear Capacitor

A linear capacitor is a basic electrical circuit element for charge storage.

Syntax

Cxxx node1 node2 [C=] value

The value of a linear capacitor may be a constant, or an expression of parameters.

Token	Description
<i>Cxxx</i>	Name of a capacitor. Shall begin with C, followed by up to 1023 alphanumeric characters.
<i>node1,node2</i>	Names of connecting nodes.
<i>value</i>	Capacitance value, in farads.

4. Voltage Shunt

A voltage shunt creates a short between two nodes.

Syntax

Vxxx node1 node2 [DC=] 0

Token	Description
<i>Vxxx</i>	Voltage shunt element name. Shall begin with K, followed by up to 1023 alphanumeric characters.
<i>node1, node 2</i>	Nodes between which the shunt is placed.
<i>DC=0</i>	The zero value is required and sets the voltage between the nodes at zero volts. The text "DC=" is optional.

5. Mutual Inductor

A mutual inductor describes inductive coupling between two defined inductors.

Syntax

Kxxx Lyyy Lzzz [K=] coupling

Token	Description
<i>Kxxx</i>	Mutual inductor element name. Shall begin with K, followed by up to 1023 alphanumeric characters.
<i>Lyyy</i>	Name of the first of two coupled inductors. This inductor shall be defined elsewhere in the file.
<i>Lzzz</i>	Name of the second of two coupled inductors. This inductor shall be defined elsewhere in the file.
<i>coupling</i>	Coefficient of mutual coupling. This is a unitless number, with magnitude > 0. If the coupling coefficient is negative, the direction of coupling reverses. This is equivalent to reversing the polarity of either of the coupled inductors. Use the K=xxx syntax when defining the coupling coefficient using a parameter name or an equation. The pre-defined parameter "k" may be

omitted.

6. Linear Inductor

Syntax

```
Lxxx node1 node2 [L =] inductance
```

Token	Description
Lxxx	Name of an inductor.
node1,node2	Names or numbers of the connecting nodes.
inductance	inductance value, in henries.

7. T-element (Ideal Transmission Line)

Syntax

```
Txxx in refin out refout Z0=val TD=val [L=val]  
+ [IC=v1, i1, v2, i2]
```

Token	Description
Txxx	Lossless transmission line element name. Shall begin with T, followed by up to 1023 alphanumeric characters.
In	Signal input node.

Refin	Ground reference for the input signal.
Out	Signal output node.
Refout	Ground reference for the output signal.
Z0	Characteristic impedance of the transmission line (Ohms).
TD	Propagation time delay of the transmission line (in seconds). If physical length (L) is specified, then units for TD are considered in seconds per meter.
L	Physical length of the transmission line, in units of meters. Default=1.

8. W-element (Coupled Transmission Line)

This section describes how to use basic transmission line simulation equations and an optional method for computing the parameters of transmission line equations.

The W-element is a versatile transmission line model that may be used to describe a variety of transmission line structures, from a simple lossless line to complex frequency-dependent lossy-coupled lines.

Syntax

```
Wxxx i1 i2 ... iN iR o1 o2 ... oN oR N=val L=val  
+ [RLGCMODEL=name | TABLEMODEL=name]
```

Token	Description
N	Number of signal conductors (excluding the reference conductor).
i1...iN	Node names for the near-end signal-conductor terminal
iR	Node name for the near-end reference-conductor terminal.
o1... oN	Node names for the far-end signal-conductor terminal
oR	Node name for the far-end reference-conductor terminal.
L	Length of the transmission line.
RLGCMODEL	Name of the RLGC model.
TABLEMODEL	Name of the frequency-dependent tabular model

The W-element supports two formats to specify transmission line properties:

- Format 1: RLGC specification
 - Internally specified in a .MODEL statement.
 - Externally specified in a different file.
- Format 2: Frequency-dependent tabular specification

Parameters in the W-element element declaration may be declared in any order. Specify the number of signal conductors, N, after the list of nodes. The nodes and parameters in the W-element element declaration may be interspersed.

Format 1: RLGC Model

The inputs of the W-element are given in per unit length matrices: R_o (DC resistance), L, G, C, R_s (skin effect), and G_d (dielectric loss)

The W-element does not limit any of the following parameters:

- Number of coupled conductors.
- Shape of the matrices.
- Line loss.
- Length or amount of frequency dependence.

The RLGC text file contains frequency-dependent RLGC matrices per unit length. The W-element also handles frequency-independent RLGC, and lossless (LC) lines. It does not support RC lines.

Because RLGC matrices are symmetrical, the RLGC model specifies only the lower triangular parts of the matrices. The syntax of the RLGC model for the W-element is:

```
.MODEL name W MODELTYPE=RLGC N=val
+ Lo=matrix_entries
+ Co=matrix_entries [Ro=matrix_entries Go=matrix_entries]
+ Rs=matrix_entries wp=val Gd=matrix_entries Rognd=val
+ Rsgnd=val Lgnd=val
```

Token	Description
N	Number of conductors (same as in the element card).

L	DC inductance matrix, per unit length $\left[\frac{\text{H}}{\text{m}}\right]$.
C	DC capacitance matrix, per unit length $\left[\frac{\text{F}}{\text{m}}\right]$.
Ro	DC resistance matrix, per unit length $\left[\frac{\Omega}{\text{m}}\right]$.
Go	DC shunt conductance matrix, per unit length $\left[\frac{\text{S}}{\text{m}}\right]$.
Rs	Skin effect resistance matrix, per unit length $\left[\frac{\Omega}{\text{m}\sqrt{\text{Hz}}}\right]$.
Gd	Dielectric loss conductance matrix, per unit length $\left[\frac{\text{S}}{\text{m}\cdot\text{Hz}}\right]$.
wp	Angular frequency of the polarization constant [radian/sec] (see Introduction to the Complex Dielectric Loss Model). When the wp value is specified, the unit of Gd becomes [S/m].
Lgnd	DC inductance value, per unit length for grounds $\left[\frac{\text{H}}{\text{m}}\right]$ (reference line).
Rognd	DC resistance value, per unit length for ground $\left[\frac{\Omega}{\text{m}}\right]$.
Rsgnd	Skin effect resistance value, per unit length for ground $\left[\frac{\Omega}{\text{m}\sqrt{\text{Hz}}}\right]$.

The following input netlist file shows RLGC input for the W-element:

```
* W-Element example, four-conductor line
```

```
W1 N=3 1 3 5 0 2 4 6 0 RLGCMODEL=example_rlc l=0.97
```

```
* RLGC matrices for a four-conductor lossy
.MODEL example_rlc W MODELTYPE=RLGC N=3
+ Lo=
+ 2.311e-6
+ 4.14e-7 2.988e-6
+ 8.42e-8 5.27e-7 2.813e-6
+ Co=
+ 2.392e-11
+ -5.41e-12 2.123e-11
+ -1.08e-12 -5.72e-12 2.447e-11
+ Ro=
+ 42.5
+ 0 41.0 + 0 0 33.5
+ Go= + 0.000609
+ -0.0001419 0.000599
+ -0.00002323 -0.00009 0.000502
+ Rs=
+ 0.00135
+ 0 0.001303
+ 0 0 0.001064
+ Gd=
+ 5.242e-13
+ -1.221e-13 5.164e-13
+ -1.999e-14 -7.747e-14 4.321e-13
```

Using RLGC Matrices

RLGC matrices in the RLGC model of the W-element are in the Maxwellian format

Format 2: Frequency-Dependent Tabular Specification

The tabular RLGC model may be used as an extension of the analytical RLGC model to model any arbitrary frequency-dependent behavior of transmission lines (this model does not support RC lines).

The W-element syntax supports tables of data (use a .MODEL statement of type w). To accomplish this, the .MODEL statement refers to .MODEL statements where the “type” is SP (described in Small-Signal Parameter Data Frequency Table Model (SP Model)), which contain the actual table data for the RLGC matrices.

Note:

To ensure accuracy, the W-element tabular model requires the following:

- R and G tables require zero frequency points.
- L and C tables require infinity frequency points as well as zero frequency points.

To specify a zero frequency point, the pre-defined DC parameter may be used. Alternatively, the f parameter in the DATA field of the SP model may be set to a value of 0. To specify an infinity frequency point, use the INFINITY token.

See also, Small-Signal Parameter Data Frequency Table Model (SP Model).

Introduction to the Complex Dielectric Loss Model

When the INCLUDEGDIMAG token = yes and there is no wp input, the W-element regards the Gd matrix as the conventional model and then automatically extracts constants for the complex dielectric model.

In conventional use, the HSPICE W-element RLGC model, frequency-dependent conductance is approximated as [Eq. 36](#).

Where, [Eq. 36](#) represents the increase of shunt conductance due to dielectric loss. These pure real non-constant functions of frequency violate causality [1]. As system operating frequency becomes significantly high even for PCB systems which use high polymer dielectric materials like FR4, the appearance of the dielectric loss becomes significant and significant non-causality of [Eq. 36](#) appears.

Frequency-Dependent Matrices

The frequency-dependent loss of the shunt conductance in the dielectric is mainly due to dielectric polarization. This polarization loss leads to a complex permittivity [xxx] for the dielectric material[2].

Equation 37

And loss tangent of the dielectric material can be specified as the ratio of imaginary part of to the real part,

Equation 38

For a single dielectric dipolar moment, complex electric permittivity can be written as,

Equation 39

Where, and are low and high frequency limits of dielectric permittivity which are real numbers. And is the angular frequency that corresponds to the polarization time constant of the dielectric material. From [Eq. 39](#), frequency-dependent complex shunt loss conductance can be expressed as [3],

Equation 40

Where, the imaginary part of the conductance contributes reactively. In cases of multiple dielectric materials surrounding the system, the complex loss conductance can be extended as linear combinations of multiple dipole moments as,

Equation 41

Since Eq. 41 satisfies the Kramers-Kronig condition, we can ensure the passivity/causality of the system. Note that when this new model is activated, the definition of Gd changes from conventional [S/m*Hz] to [S/m].

Small-Signal Parameter Data Frequency Table Model (SP Model)

The small-signal parameter data frequency table model (SP model) is a generic model that describes frequency-varying behavior.

Syntax

```
.MODEL name sp [N=val FSTART=val FSTOP=val NI=val  
+ SPACING=val MATRIX=val VALTYPE=val INFINITY=matrixval  
+ INTERPOLATION=val EXTRAPOLATION=val] [DATA=(npts ...)]  
+ [DATAFILE=filename]
```

Parameter Description

Token	Description
N	Matrix dimension (number of signal terminals). Default is 1. If you use a value other than the default, you must specify that value before you set INFINITY and DATA
FSTART	Starting frequency point for data. Default=0.
FSTOP	Final frequency point for data. Use this parameter only for the LINEAR and LOG spacing formats.
NI	Number of frequency points per interval. Use this parameter only for the DEC and OCT spacing formats. Default=10.

SPACING	<p>Data sample spacing format:</p> <ul style="list-style-type: none"> • LIN (LINEAR): uniform spacing with frequency step of $(FSTOP-FSTART)/(npts-1)$. The default. • OCT: octave variation with FSTART as the starting frequency and NI points per octave. npts sets the final frequency. • DEC: decade variation with FSTART as the starting frequency and NI points per decade. npts sets the final frequency. • LOG: logarithmic spacing. FSTART and FSTOP are the starting and final frequencies. • POI: non-uniform spacing. Pairs data (NONUNIFORM) points with frequency points.
MATRIX	<p>Matrix (data point) format:</p> <ul style="list-style-type: none"> • SYMMETRIC: symmetric matrix. Specifies only lower-half triangle of a matrix (default). • HERMITIAN: similar to SYMMETRIC; off-diagonal terms are complex conjugates of each other. • NONSYMMETRIC: non-symmetric (full) matrix.
VALTYPE	<p>Data type of matrix elements:</p> <ul style="list-style-type: none"> • REAL: real entry. • CARTESIAN: complex number in real/imaginary format (default). • POLAR: complex number in polar format. Specify angles in radians.
INFINITY	<p>Data point at infinity. Typically real-valued. This data format must be consistent with MATRIX and VALTYPE specifications. Npts does not count this point.</p>
INTERPOLATION	<p>Interpolation scheme:</p> <ul style="list-style-type: none"> • STEP: piecewise step (default). • LINEAR: piecewise linear. • SPLINE: b-spline curve fit.
EXTRAPOLATION	<p>Extrapolation scheme during simulation:</p> <ul style="list-style-type: none"> • NONE: no extrapolation is allowed. Simulation terminates if a required data point is outside of the specified range. • STEP: uses the last boundary point. The default. • LINEAR: linear extrapolation by using the last two boundary points.

If the data point at infinity is specified, then extrapolation is not used.

npts	Number of data points.
DC	Data port at DC. Normally real-valued. This data format must be consistent with MATRIX and VALTYPE specifications. npts does not count this point. You must specify either the DC point or the data point at frequency=0.
DATA	Data points. <ul style="list-style-type: none">• Syntax for LIN spacing: .MODEL name sp SPACING=LIN [N=dim] FSTART=f0 + DF=f1 DATA=npts d1 d2 ...• Syntax for OCT or DEC spacing: .MODEL name sp SPACING=DEC or OCT [N=dim] + FSTART=f0 NI=n_per_intval DATA=npts d1 d2 ...• Syntax for POI spacing: .MODEL name sp SPACING=NONUNIFORM [N=dim] + DATA=npts f1 d1 f2 d2 ...
DATAFILE	Data points in an external file. This file must contain only raw numbers without any suffixes, comments or continuation letters. The first number in the file must be an integer value to indicate the number of sampling points in the file. Then, sampling data must follow. The order of sampling data must be the same as in the DATA statement. This data file has no limitation on line length.

W-element Model Definition Syntax

```
.MODEL name W MODELTYPE=TABLE [FITGC=0|1] N=val  
+ LMODEL=l_freq_model CMODEL=c_freq_model  
+ [RMODEL=r_freq_model GMODEL=g_freq_model]
```

Token	Description
FITGC	Pre-defined parameter token for the W-element with MODELTYPE=TABLE. A value of 1 instructs the tool to run a causality check on the data. A value of 0 turns any causality checking off (default)

N	Number of signal conductors (excluding the reference conductor).
LMODEL	SP model name for the inductance matrix array.
CMODEL	SP model name for the capacitance matrix array.
RLMODEL	SP model name for the resistance matrix array. By default, it is zero.
GMODEL	SP model name for the conductance matrix array. By default, it is zero.

9. S-element

An S-element is a frequency-domain set of network data, described using scattering parameters.

Syntax

```
Sxxx nd1 nd2 ... ndN [ndRef]
```

```
+ MNAME=Smodel_name
```

```
+ [FBASE = base_frequency] [FMAX=maximum_frequency]
```

Token	Description
nd1 nd2...ndN	Nodes of an S-element Three kinds of definitions are present: <ul style="list-style-type: none">■ With no reference node ndRef, the default reference node is GND. Each node ndi (i=1~N) and GND construct one of the N ports of the S-element.■ With one reference node, ndRef is defined. Each node ndi (i=1~N) and the ndRef construct one of the N ports of the S-element.■ With an N reference node, each port has its own reference node. The node definition may be written more clearly: nd1+ nd1- nd2+ nd2- ... ndN+ ndN- Each pair of the nodes (ndi+ and ndi-, i=1~N) constructs one of the N ports of the S-element.
ndRef	Reference node
MNAME	Name of the S model; Note that string parameters are supported in calling an MNAME.

FBASE	<p>Base frequency to use for transient analysis. This value becomes the base frequency point for Inverse Fast Fourier Transformation (IFFT).</p> <ul style="list-style-type: none"> ■ If this value is not set, the base frequency is a reciprocal value of the transient period. ■ If a frequency is set that is smaller than the reciprocal value of the transient, then transient analysis performs circular convolution, and uses the reciprocal value of FBASE as its base period.
FMAX	<p>Maximum frequency use in transient analysis. Used as the maximum frequency point for Inverse Fast Fourier Transformation (IFFT).</p>

The nodes of the S-element be placed immediately after the identifier token. All optional parameters in both the S-element and S model statements may be defined by the user, except for MNAME argument.

The optional arguments may be entered in any order, and the parameters specified in the element statement have a higher priority.

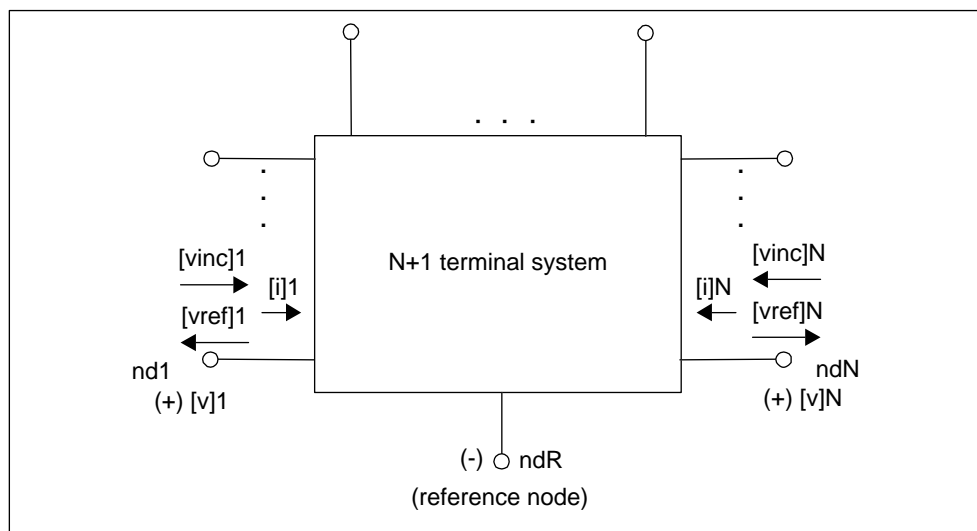

Figure 27 Terminal Node Notation

Node Example

The following example illustrates the $nd1\ nd2\dots ndN$ —no reference, single reference, and multi-reference parameters.

```

**S-parameter example

* no reference
S_no_ref n1 n2 mname=s_model

* single reference
S_one_ref n1 n3 gnd mname=s_model

*multi-reference
S_multi_ref n1 gnd n4 gnd mname=s_model

```

The S-element must have a call to one of the supported S-parameter file formats (IBIS-ISS gets the number of ports from the S-parameter file The number of ports, 'n', may be specified explicitly as N=n.

- For n terminals, the S-element assumes no reference node.
- For n+1 terminals, the S-element assumes one reference node.
- For 2n terminals, the S-element assumes signal nodes and n reference nodes. Each pair of nodes is a signal and a reference node.

S Model Syntax

Use the following syntax to describe specific S models:

```

.MODEL Smodel_name S [N=dimension]
+ [TSTONEFILE=filename]

+ [FBASE=base_frequency] [FMAX=maximum_frequency]

```

Token	Description
<i>Smodel_name</i>	Name of the S model.
S	Specifies that the model type is an S model.
N	S model dimension, which is equal to the terminal number of an S-element and excludes the reference node.

TSTONEFILE	<p>Specifies the name of a Touchstone file. Data contains frequency-dependent array of matrixes. Touchstone files must follow the .s#p file extension rule, where # represents the dimension of the network. Note that string parameters are supported for TSTONEFILE</p> <p>Example:</p> <pre>.subckt sparam n1 n2 tsfile=str('ss_ts.s2p') S1 n1 n2 0 mname=s_model .model s_model S TSTONEFILE=str(tsfile) .ends x1 A B sparam tsfile=str('ss_ts.s2p') ...</pre> <p>For details, see <i>Touchstone® File Format Specification</i> by the IBIS Open Forum (http://www.eda.org/ibis/).</p>
FBASE	<p>Base frequency used for transient analysis. IBIS-ISS uses this value as the base frequency point for Fast Inverse Fourier Transformation (IFFT).</p> <ul style="list-style-type: none"> ■ If FBASE is not set, IBIS-ISS uses a reciprocal of the transient period as the base frequency. ■ If FBASE is set smaller than the reciprocal value of transient period, transient analysis performs circular convolution by using the reciprocal value of FBASE as a base period.
FMAX	<p>Maximum frequency for transient analysis. Used as the maximum frequency point for Inverse Fast Fourier Transform (IFFT).</p>

The, TSTONEFILE parameters describe the frequency-varying behavior of a network.

10. E-element (Voltage-Controlled Voltage Source)

This section explains the E-element syntax and parameters.

Linear

```
Exxx n+ n- [VCVS] in+ in- gain
```

For a description of these parameters, [see table VCVS Parameters](#).

Laplace Transform

Voltage Gain H(s):

```
Exxx n+ n- LAPLACE in+ in- k0, k1, ..., kn / d0,
      d1, ..., dm
```

For a description of these parameters, [see table VCVS Parameters](#).

H(s) is a rational function, with parameters used to define the values of all coefficients (k₀, k₁, ..., d₀, d₁, ...).

Pole-Zero Function

Voltage Gain H(s):

```
Exxx n+ n- POLE in+ in- a az1, fz1, ..., azn, fzn / b,
+ ap1, fp1, ..., apm, fpm
```

For a description of these parameters, [see table VCVS Parameters](#).

The following equation defines H(s) in terms of poles and zeros:

$$H(s) = \frac{a \cdot (s + \alpha_{z1} - j2\pi f_{z1}) \dots (s + \alpha_{zn} - j2\pi f_{zn})(s + \alpha_{zn} + j2\pi f_{zn})}{b \cdot (s + \alpha_{p1} - j2\pi f_{p1}) \dots (s + \alpha_{pm} - j2\pi f_{pm})(s + \alpha_{pm} + j2\pi f_{pm})}$$

The complex poles or zeros are in conjugate pairs. The element description specifies only one of them, and the program includes the conjugate. Parameters may be used to specify the a, b, α , and f values.

Example

```
Elow_pass out 0 POLE in 0 1.0 / 1.0, 1.0,0.0 0.5,0.1379
```

The `Elow_pass` statement describes a low-pass filter, with the transfer function:

$$H(s) = \frac{1.0}{1.0 \cdot (s + 1)(s + 0.5 + j2\pi \cdot 0.1379)(s + 0.5 - (j2\pi \cdot 0.1379))}$$

Foster Pole-Residue Form

Gain E(s) form

```

Exxxx n+ n- FOSTER in+ in- k0 k1
+ (Re{A1}, Im{A1}) / (Re{p1}, Im{p1})
+ (Re{A2}, Im{A2}) / (Re{p2}, Im{p2})
+ (Re{A3}, Im{A3}) / (Re{p3}, Im{p3})
+ ...

```

For a description of these parameters, see [Common Source Parameters](#).

In the above syntax, parentheses, commas, and slashes are separators—they have the same meaning as a space. A pole-residue pair is represented by four numbers (real and imaginary part of the residue, then real and imaginary part of the pole).

For convergence, the Re[pi] must be less than zero. For an N-port admittance matrix Y, Re{Y} should be positive-definite to ensure passivity of the model.

Note:

For real poles, half the residue value is entered because it is applied twice. In the above example, the first pole-residue pair is real, but is written as “A1/(s-p1)+A1/(s-p1)”; therefore, 0.0004 is entered rather than 0.0008.

E-element Parameters

The E-element parameters are described in the following list.

Token	Description
Exxx	Voltage-controlled element name. Must begin with E, followed by up to 1023 alphanumeric characters.
gain	Voltage gain.
in +/-	Positive or negative controlling nodes. Specify one pair for each dimension.
K	Ideal transformer turn ratio: $V(\text{in+},\text{in-}) = k \cdot V(\text{n+},\text{n-})$ or, number of gates input.
n+/-	Positive or negative node of a controlled element.
VCVS	Pre-defined token for a voltage-controlled voltage source. VCVS is a reserved word; do not use it as a node name.

11. F-element (Current-Controlled Current Source)

This section explains the F-element syntax and parameters.

Note:

G-elements with algebraic expressions may be used to duplicate the functions of an F-element.

Syntax

```
Fxxx n+ n- [CCCS] vn1 gain
```

F-element Parameters

The F-element parameters are described in the following list.

Token	Description
CCCS	Pre-defined token for current-controlled current source. CCCS is a IBIS-ISS reserved word; do not use it as a node name.
Fxxx	Element name of the current-controlled current source. Must begin with F, followed by up to 1023 alphanumeric characters.
gain	Current gain.
n+/-	Connecting nodes for a positive or negative controlled source.
vn1 ...	Names of voltage sources, through which the controlling current flows. Specify one name for each dimension.
x1,...	Controlling current, through the <i>vn1</i> source. Specify the <i>x</i> values in increasing order.
y1,...	Corresponding output current values of <i>x</i> .

12. G-element (Voltage-Controlled Current Source)

This section explains G-element syntax statements, and their parameters.

Linear

Gxxx n+ n- [VCCS] in+ in- transconductance

For a description of the G-element parameters, see Table VCCS Parameters.

Laplace Transform

Transconductance H(s):

Gxxx n+ n- LAPLACE in+ in- k0, k1, ..., kn / d0, d1, ..., dm

H(s) is a rational function, in the following form:

$$H(s) = \frac{k_0 + k_1s + \dots + k_ns^n}{d_0 + d_1s + \dots + d_ms^m}$$

Parameters may be used to define the values of all coefficients (k₀, k₁, ..., d₀, d₁, ...).

Pole-Zero Function

Transconductance H(s):

Gxxx n+ n- POLE in+ in- a az1, fz1, ..., azn, fzn / b, + ap1, fp1, ..., apm, fpm

The following equation defines H(s) in terms of poles and zeros:

$$H(s) = \frac{a \cdot (s + \alpha_{z1} - j2\pi f_{z1}) \dots (s + \alpha_{zn} - j2\pi f_{zn})(s + \alpha_{zn} + j2\pi f_{zn})}{b \cdot (s + \alpha_{p1} - j2\pi f_{p1}) \dots (s + \alpha_{pm} - j2\pi f_{pm})(s + \alpha_{pm} + j2\pi f_{pm})}$$

The complex poles or zeros are in conjugate pairs. The element description specifies only one of them, and the simulation program will include the conjugate automatically. Parameters may be used to specify the a, b, α , and f values.

For a description of the G-element parameters, see Common Source Parameters.

Example

Ghigh_pass 0 out POLE in 0 1.0 0.0,0.0 / 1.0 0.001,0.0

The `Ghigh_pass` statement describes a high-pass filter, with the transfer function:

$$H(s) = \frac{1.0 \cdot (s + 0.0 + j \cdot 0.0)}{1.0 \cdot (s + 0.001 + j \cdot 0.0)}$$

Foster Pole-Residue Form

Transconductance $G(s)$ form

```
Gxxx n+ n- FOSTER in+ in- k0 k1
+ (Re{A1}, Im{A1}) / (Re{p1}, Im{p1})
+ (Re{A2}, Im{A2}) / (Re{p2}, Im{p2})
+ (Re{A3}, Im{A3}) / (Re{p3}, Im{p3})
+ ...
```

In the above syntax, parenthesis, commas, and slashes are separators—they have the same meaning as a space. A pole-residue pair is represented by four numbers (real and imaginary part of the residue, then real and imaginary part of the pole).

For convergence, the $\text{Re}[p_i]$ shall be less than zero. For an N -port admittance matrix Y , $\text{Re}\{Y\}$ should be positive-definite to ensure passivity of the model.

For a description of the G -element parameters, see [Common Source Parameters](#).

Example

To represent a $G(s)$ in the form,

$$G(s) = 0.001 + 1 \times 10^{-12} s + \frac{0.0008}{s + 1 \times 10^{10}} + \frac{(0.001 - j0.006)}{s - (-1 \times 10^8 + j1.8 \times 10^{10})} + \frac{(0.001 + j0.006)}{s - (-1 \times 10^8 - j1.8 \times 10^{10})}$$

The IBIS-ISS syntax is:

```
G1 1 0 FOSTER 2 0 0.001 1e-12
+(0.0004, 0)/(-1e10, 0) (0.001, -0.006)/(-1e8, 1.8e10)
```

Note:

For real poles, half the residue value is entered because it is applied twice. In the above example, the first pole-residue pair is real, but is

written as $A1/(s-p1)+A1/(s-p1)$ "; therefore, 0.0004 is entered rather than 0.0008.

G-element Parameters

The G-element parameters are described in the following list.

Token	Description
Gxxx	Name of the voltage-controlled element. Must begin with G, followed by up to 1023 alphanumeric characters.
in +/-	Positive or negative controlling nodes. Specify one pair for each dimension.
n+/-	Positive or negative node of the controlled element.
transconductance	Voltage-to-current conversion factor.
VCCS	Pre-defined token for the voltage-controlled current source. VCCS is a reserved IBIS-ISS word; do not use it as a node name.
x1,...	Controlling voltage, across the <i>in+</i> and <i>in-</i> nodes. Specify the <i>x</i> values in increasing order.
y1,...	Corresponding element values of <i>x</i> .

13. H-element (Current-Controlled Voltage Source)

This section explains H-element syntax statements, and defines their parameters.

Note:

The E-element with algebraic expressions may be used to duplicate the function of the H-element.

Syntax

```
Hxxx n+ n- [CCVS] vnl transresistance
```

Token	Description
CCVS	Pre-defined token for the current-controlled voltage source. CCVS is a IBIS-ISS reserved word; do not use it as a node name.
Hxxx	Element name of current-controlled voltage source. Must start with H, followed by up to 1023 alphanumeric characters.
n+/-	Connecting nodes for positive or negative controlled source.
transresistance	Current-to-voltage conversion factor.
vn1 ...	Names of voltage sources, through which controlling current flows. One name for each dimension shall be specified.
x1,...	Controlling current, through the <i>vn1</i> source. Specify the <i>x</i> values in increasing order.
y1,...	Corresponding output voltage values of <i>x</i> .

14. Common Source Parameters

Input parameters common to all sources are shown in the following list.

Token	Description
ABS	Output is an absolute value if ABS=1.
DELAY	Pre-defined token for the delay element, corresponding to propagation delay of the source. DELAY is a reserved word, which shall not be used as a node name.

DELTA	Controls the curvature of the piecewise linear corners. This parameter defaults to one-fourth of the smallest distance between breakpoints. The maximum is one-half of the smallest distance between breakpoints.
Exxx	Voltage-controlled element name. Must begin with E, followed by up to 1023 alphanumeric characters.
gain	Voltage gain.
gatetype(k)	Can be AND, NAND, OR, or NOR. k represents the number of inputs of the gate. x and y represent the piecewise linear variation of output, as a function of input. In multi-input gates, only one input determines the state of the output.
IC	Initial condition: initial estimate of controlling voltage value(s). If IC is not specified, the default=0.0.
in +/-	Positive or negative controlling nodes. Specify one pair for each dimension.
k	Ideal transformer turn ratio: $V(in+,in-) = k \oplus V(n+,n-)$ or number of gates input.
MAX	Maximum output voltage value. The default is undefined, and sets no maximum value.
MIN	Minimum output voltage value. The default is undefined, and sets no minimum value.
n+/-	Positive or negative node of a controlled element.
NDIM	Number of polynomial dimensions. If POLY(NDIM) is not set, a one-dimensional polynomial shall be assumed. NDIM must be a positive number.

NPDELAY Sets the number of data points to use in delay simulations. The default value is the larger of either 10, or the smaller of TD/tstep and tstop/tstep. That is,

$$NPDELAY_{default} = \max\left(\frac{\min(TD, tstop)}{tstep}, 10\right)$$

The .TRAN statement specifies tstep and tstop values.

LEVEL=x Interchangeable function token such as VCCS, VCAP, etc.

OPAMP or Level=1 or Level=1

P0, P1 ... The polynomial coefficients.
 If only one coefficient is specified, the simulation engine shall assume it to be P1 (P0=0.0), and that the element is linear. If more than one polynomial coefficient is specified, the element shall be assumed nonlinear, and P0, P1, P2 ... shall be assumed to represent them.

POLY Token for the polynomial function. If POLY(ndim) is not specified, the engine shall assume a one-dimensional polynomial. ndim must be a positive number.

PWL Token for the piecewise linear function.

SCALE Multiplier for the element value.

TC1,TC2 First-order and second-order temperature coefficients. Temperature changes update the SCALE:

$$SCALE_{eff} = SCALE \oplus (1 + TC1 \oplus \otimes t + TC2 \oplus \otimes t^2)$$

TD Token for the time (propagation) delay.

13. Best Practices

This section details syntax recommendations for ensuring maximum compatibility with existing proprietary SPICE variants. While not requirements for IBIS-ISS, following these practices will help maintain the portability of IBIS-ISS files.

- Scaling of interconnect subcircuits may give different results between different simulators and should be avoided.
- Global parameters may give different results between different simulators and should be avoided.
- Exponent range should be limited to between e-60 and e+60.
- For maximum compatibility, IBIS-ISS does not support the “X” (Meg) scale factor..
- A name field should begin with [a-z] or [A-Z]. The remaining characters of a name field should be limited to
 - [a-z], [A-Z], [0-9], ~!@#%&_<>?[]|:;
- Parameter names should begin with [a-z] or [A-Z], and the remaining characters should be limited to
 - [a-z] or [A-Z], [0-9], ! # \$ % []
- While a parameter may be defined in more than one .param statement within a subckt, this practice is best avoided.
- Node names should either be all numeric [0-9], or be a name field.