Differential buffer using IBIS models for PDN simulations

Lance Wang
Asian IBIS Summit – Yokohama
Nov. 20th, 2014



Outline

This is a case study for differential pair buffers in Power Delivery Network (PDN) simulations

- Motivation
- Review IBIS PDN feature for single-end buffer
- Power currents using non-PDN IBIS model and IBIS with PDN feature for differential pair buffer in simulation
- Average-Out approach for differential buffer PDN simulation
- Summary

Motivation

- Many times we need to do a PDN simulation with differential pair buffers in the network using IBIS models
- IBIS Spec doesn't include how to make IBIS PDN model for differential pair buffers
- Seeking a reasonable solution for differential buffer PDN simulation using existing IBIS modeling specification

The test case

- LVDS 1.5v true-differential buffer
- We have access to each pin/buffer power supply
- Positive and negative pin buffer are identical
- Push-up and Pull-down are almost even
- We are checking on Driver side only

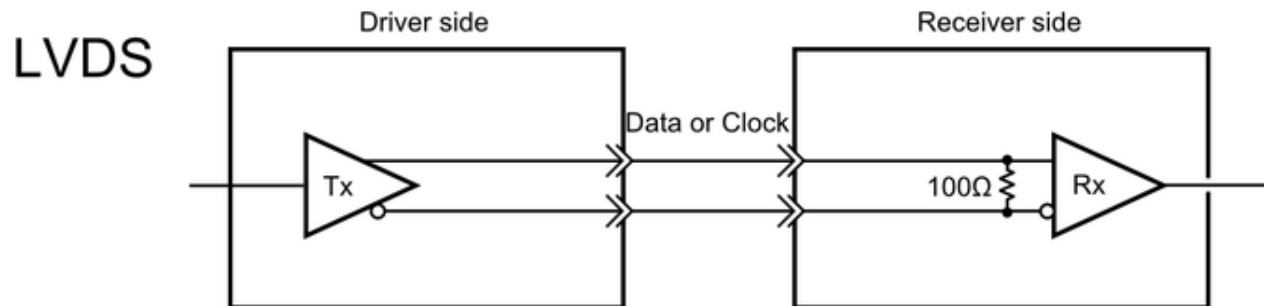

Review of IBIS PDN Feature

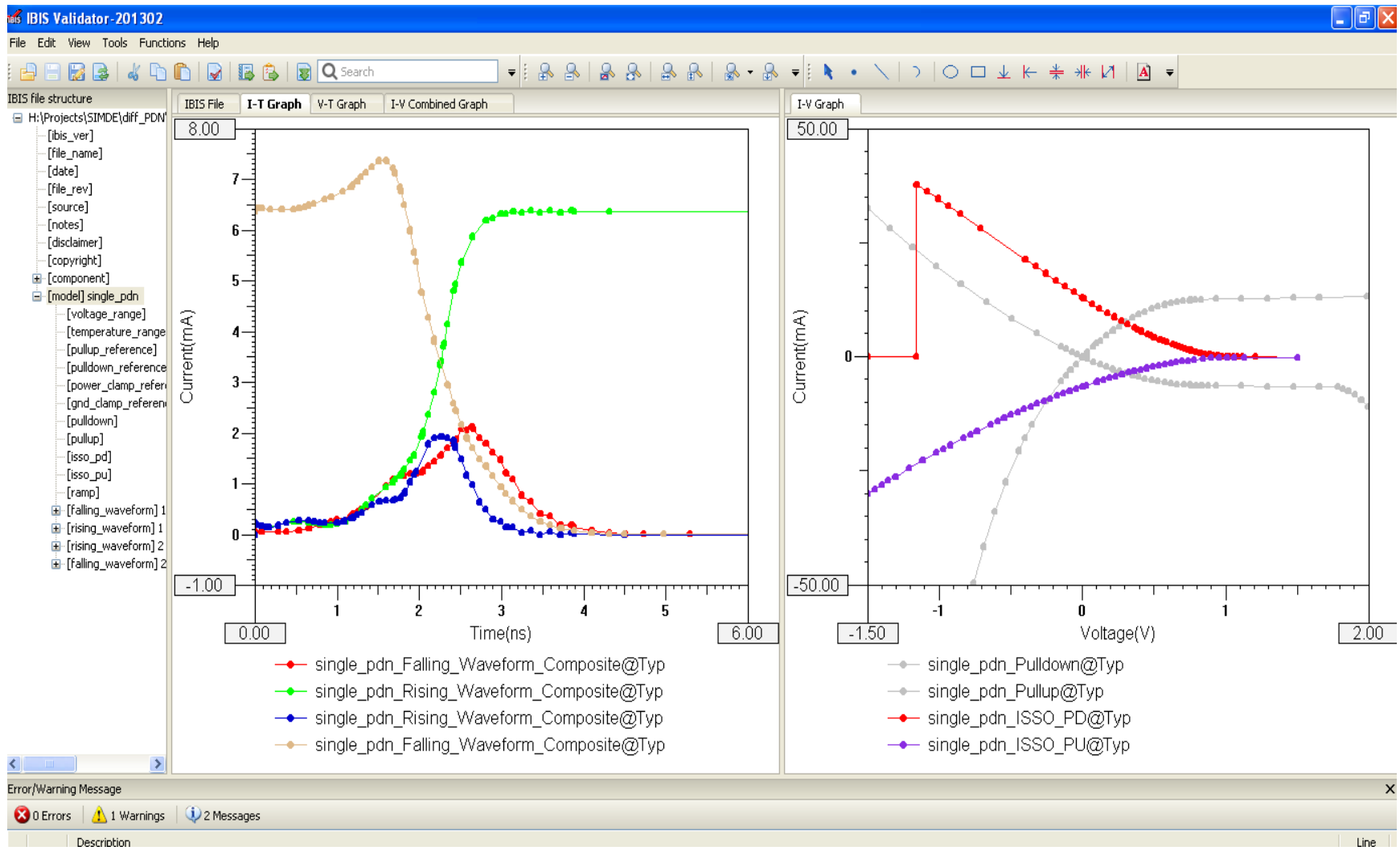

Test circuit and results (Power)

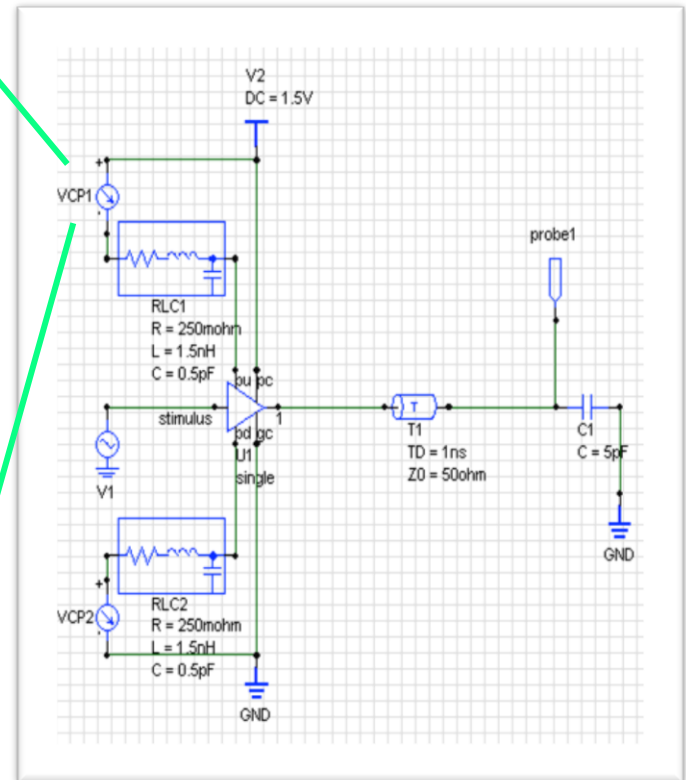
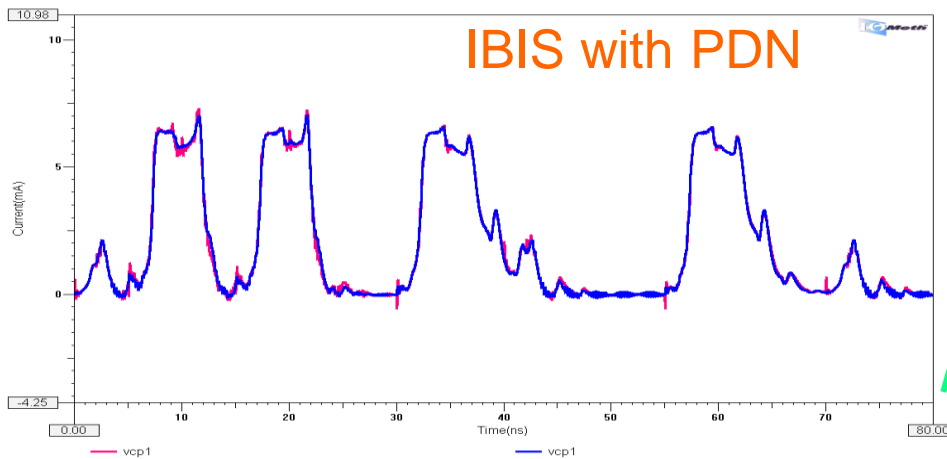
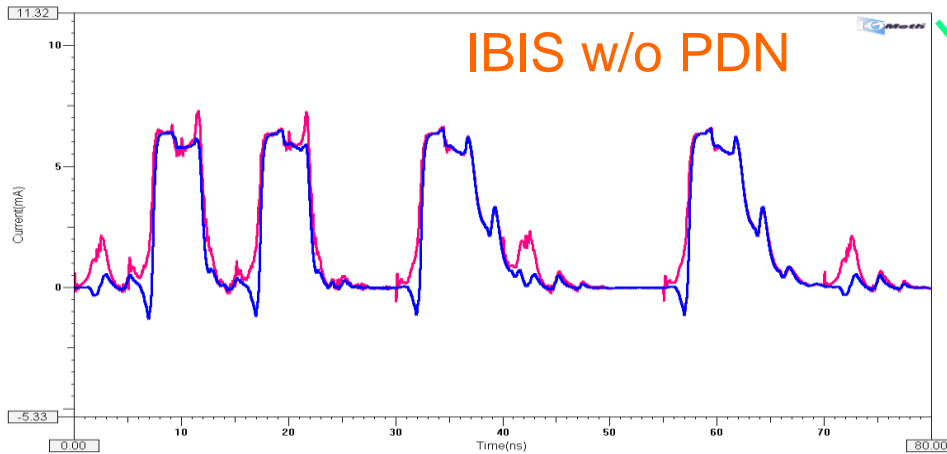

RED: Spice BLUE:IBIS

Test circuit and results (Ground)

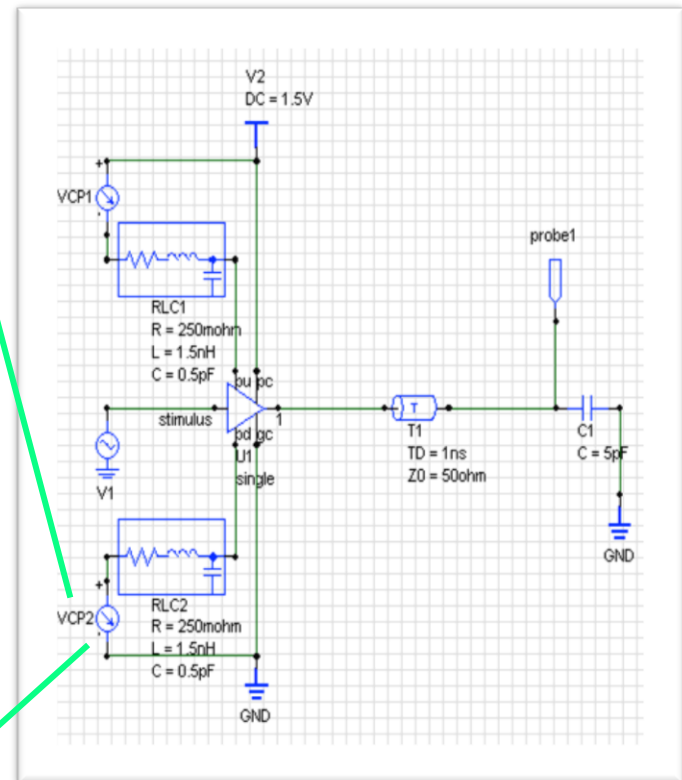
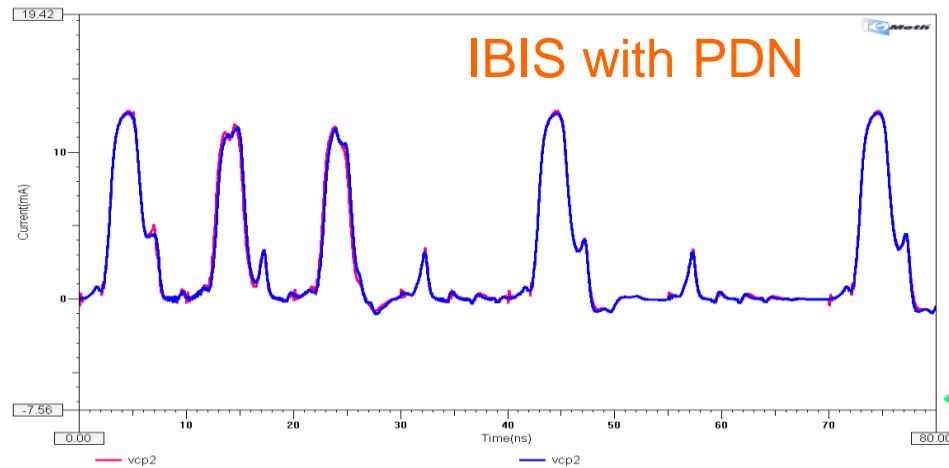
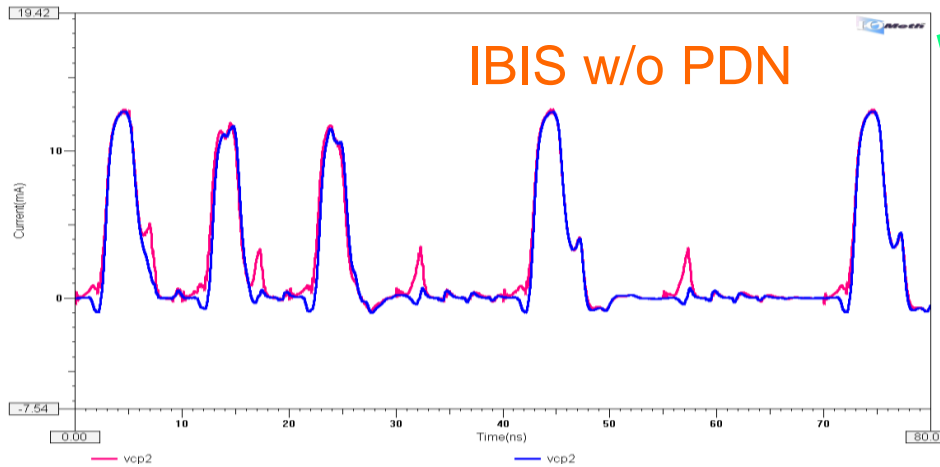

RED: Spice BLUE:IBIS

Differential pair buffer result (IBIS without PDN feature)

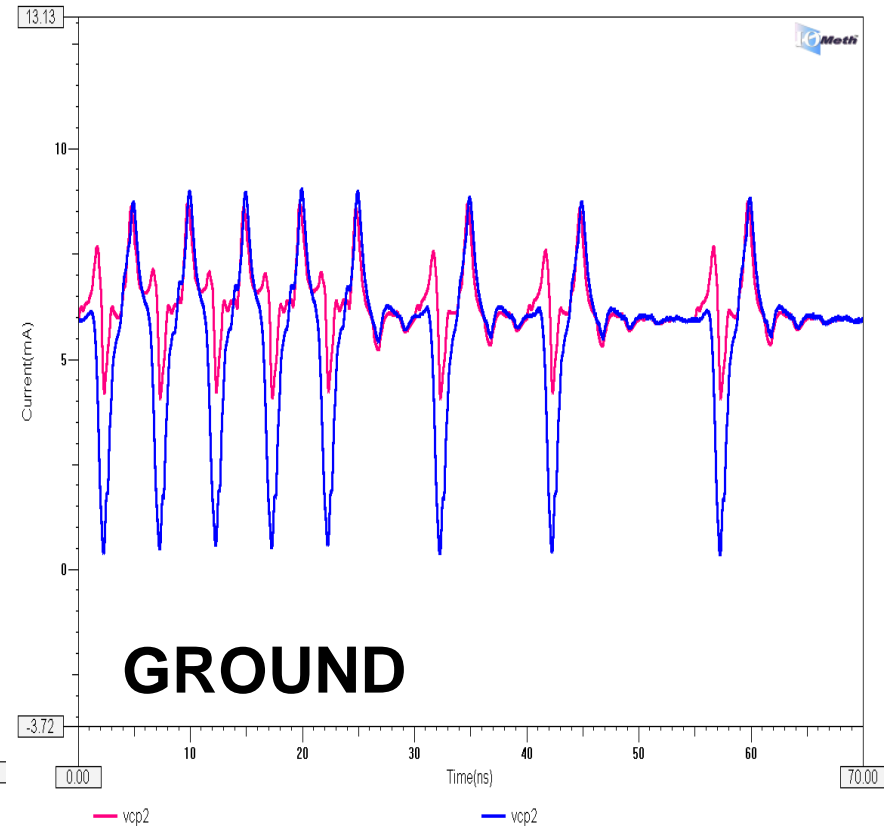
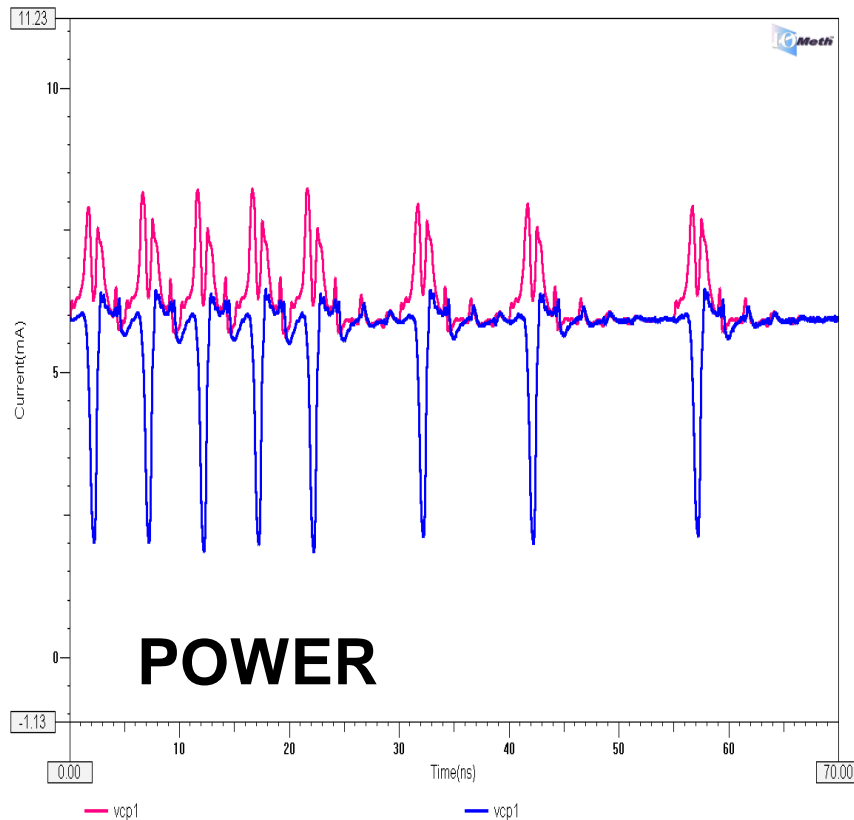

RED: Spice BLUE:IBIS

Differential pair buffer result (IBIS with PDN feature) – Extracted from single pins

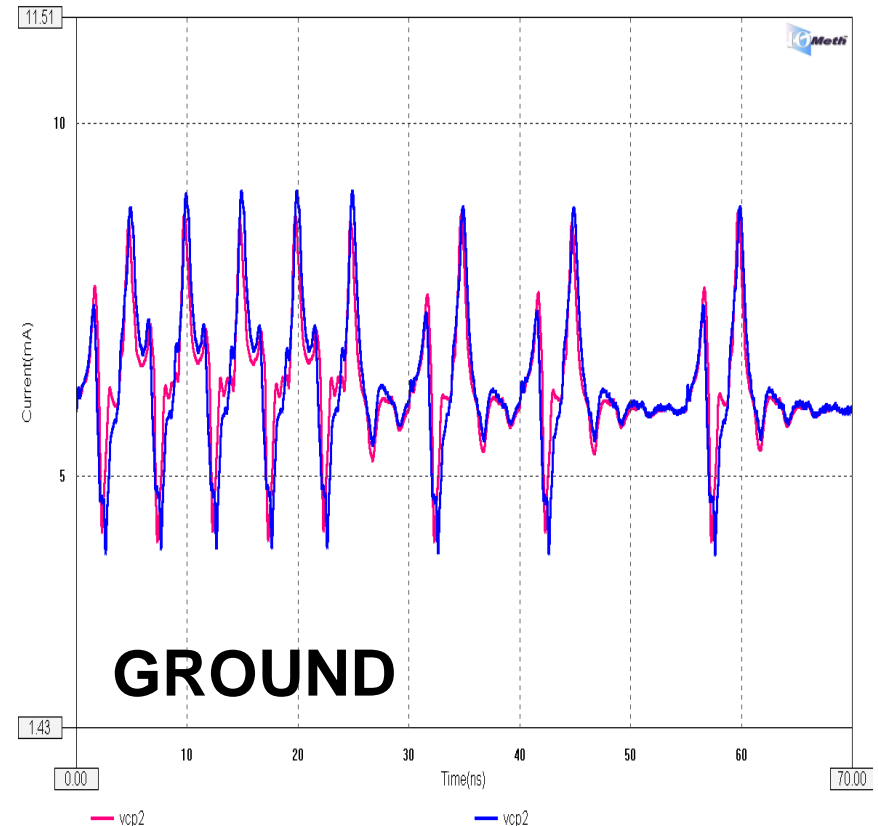
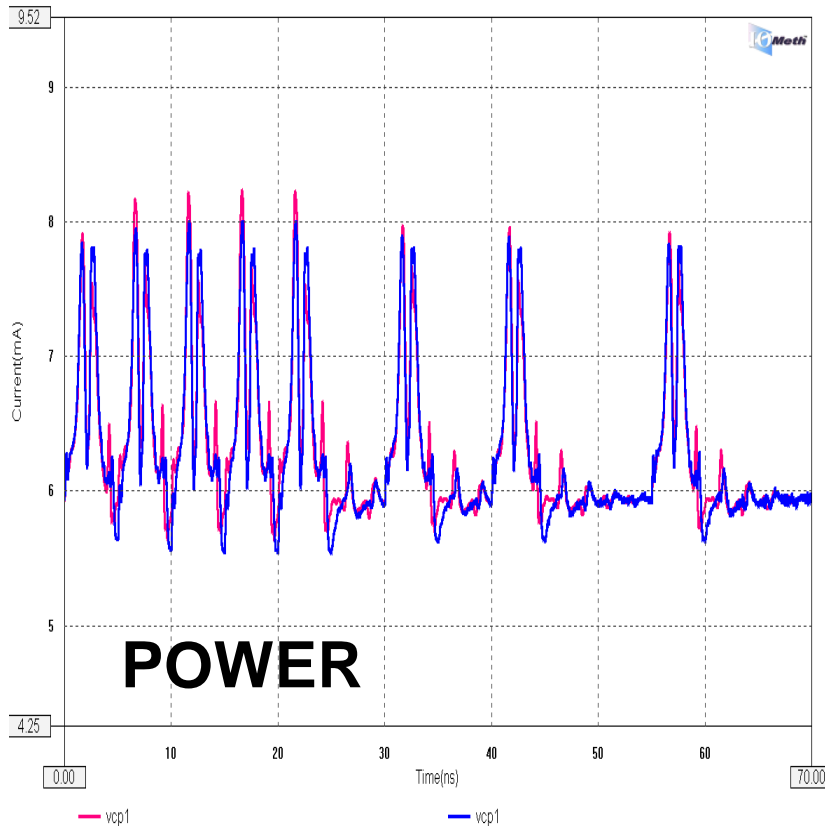

RED: Spice BLUE:IBIS

Differential pair PDN simulation analysis

- Result using IBIS model without PDN features is not acceptable
- Result using IBIS model with PDN features is GOOD!
 - This result is using the IBIS model extracted from separate power source for each P/N pins

What if we don't have the access to each buffers power pins?

Look into the [Composite Current] curve

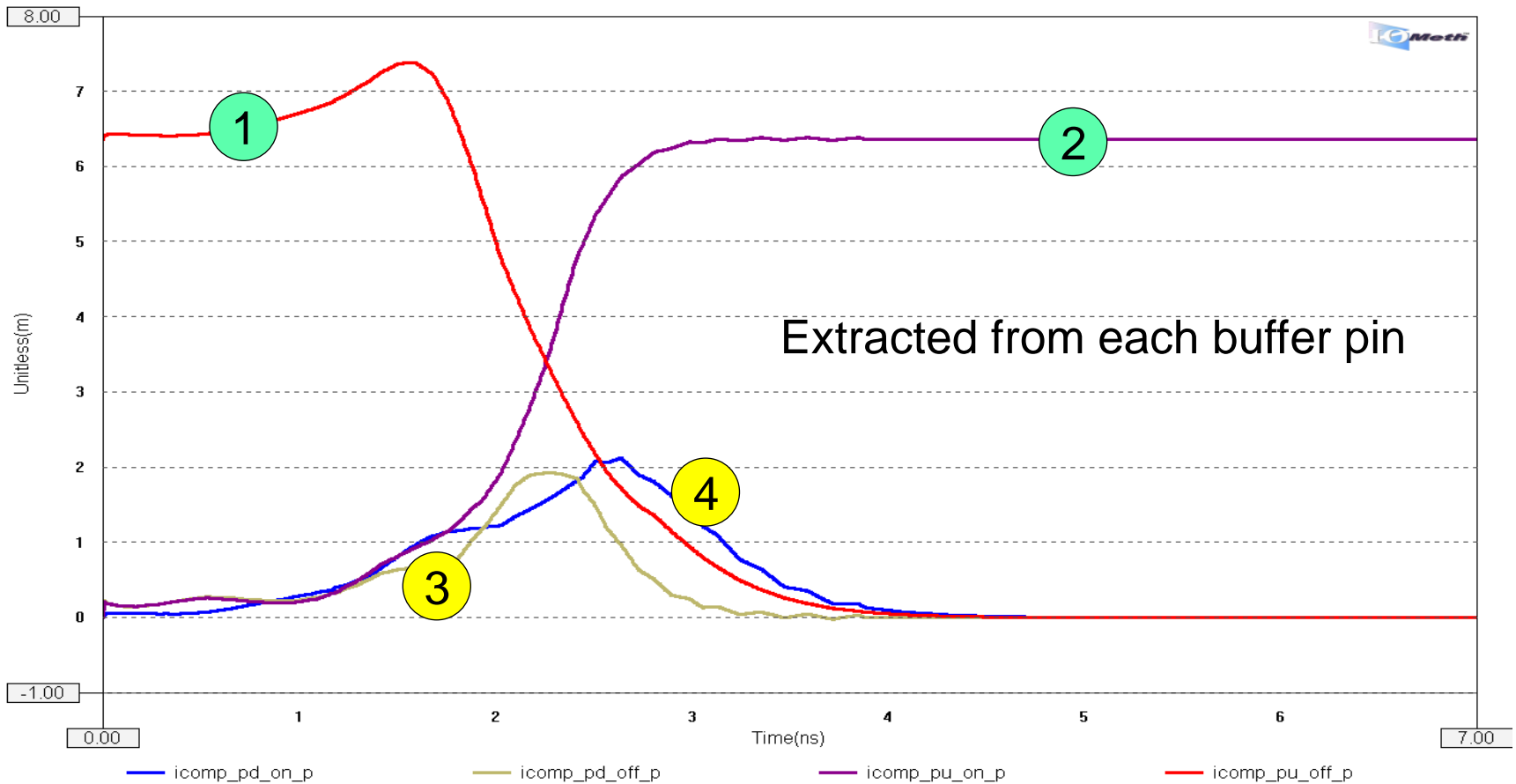

Look into the [Composite Current] curve

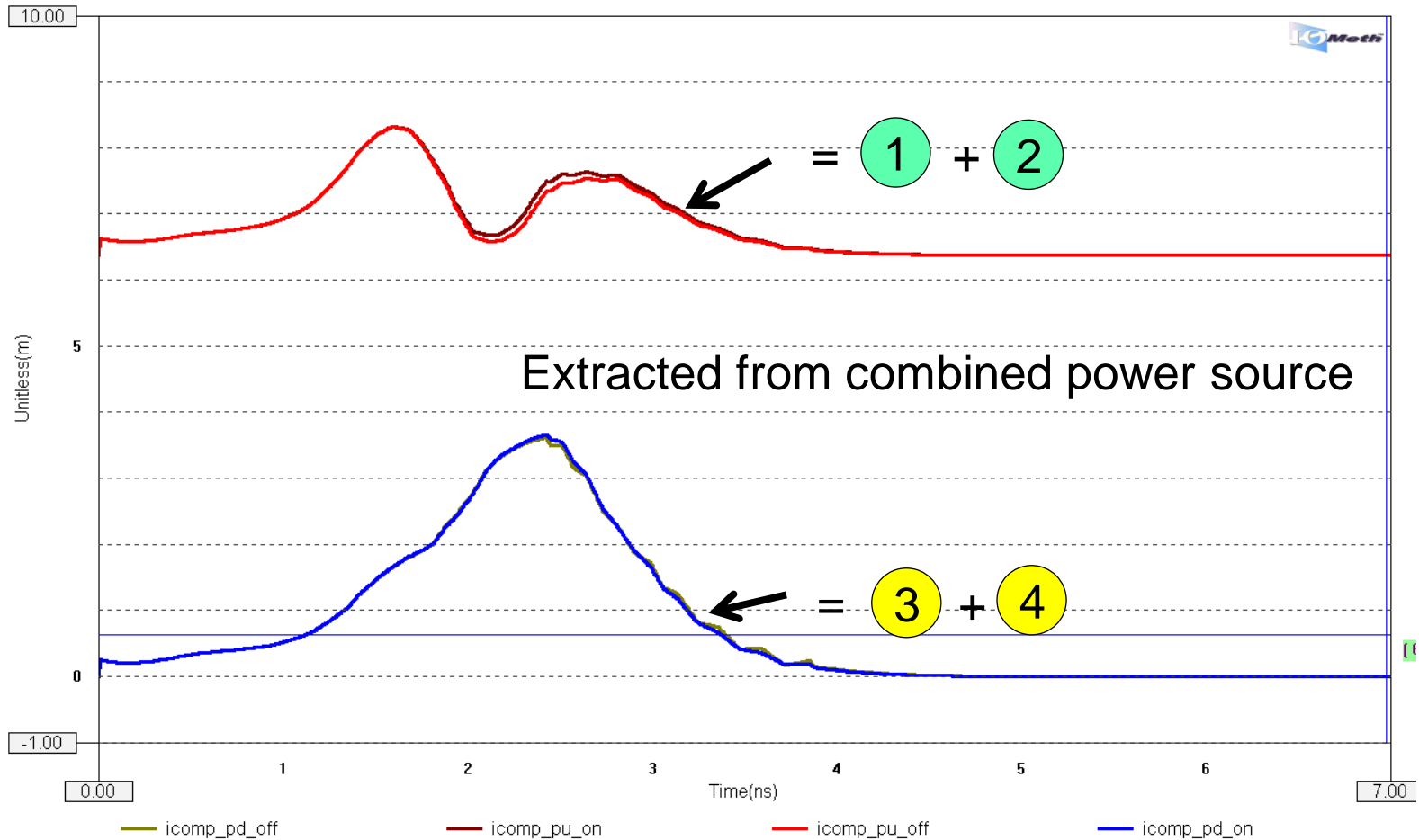

ISSO* and Composite Current curves for combined power source

- We can get combined ISSO* by setting up both Pullup or Pulldown then take the average for each buffer
- Due to actual P/N pins take one pullup and one pulldown at the same time for differential pair, Composite Current we get is (1)+(2) and (3)+(4)
 - We can also do an average-out to see if it would close to the Spice simulation results

Result for combined POWER pin

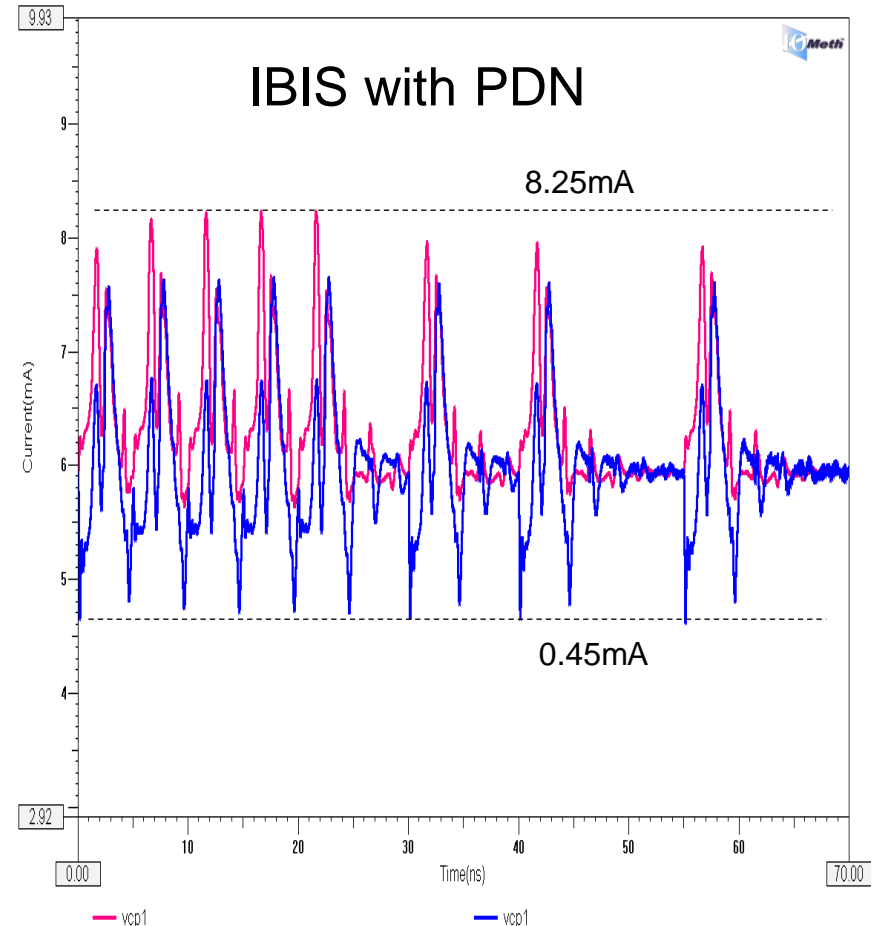
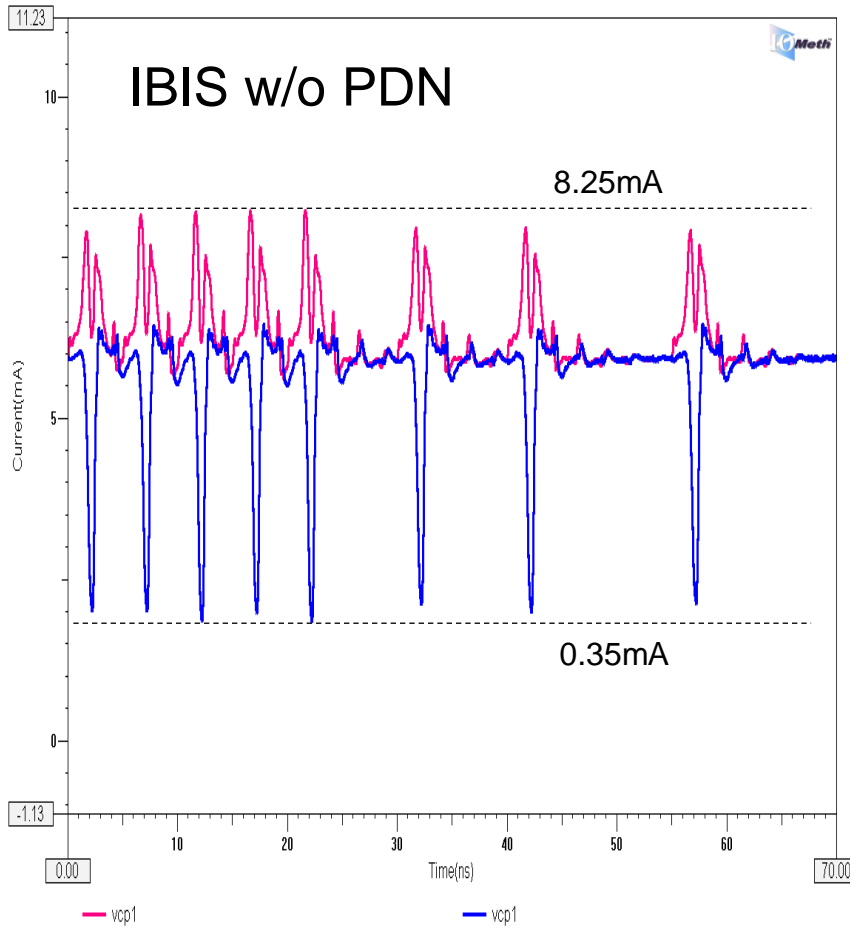

RED: Spice BLUE:IBIS

Result for combined GROUND pin

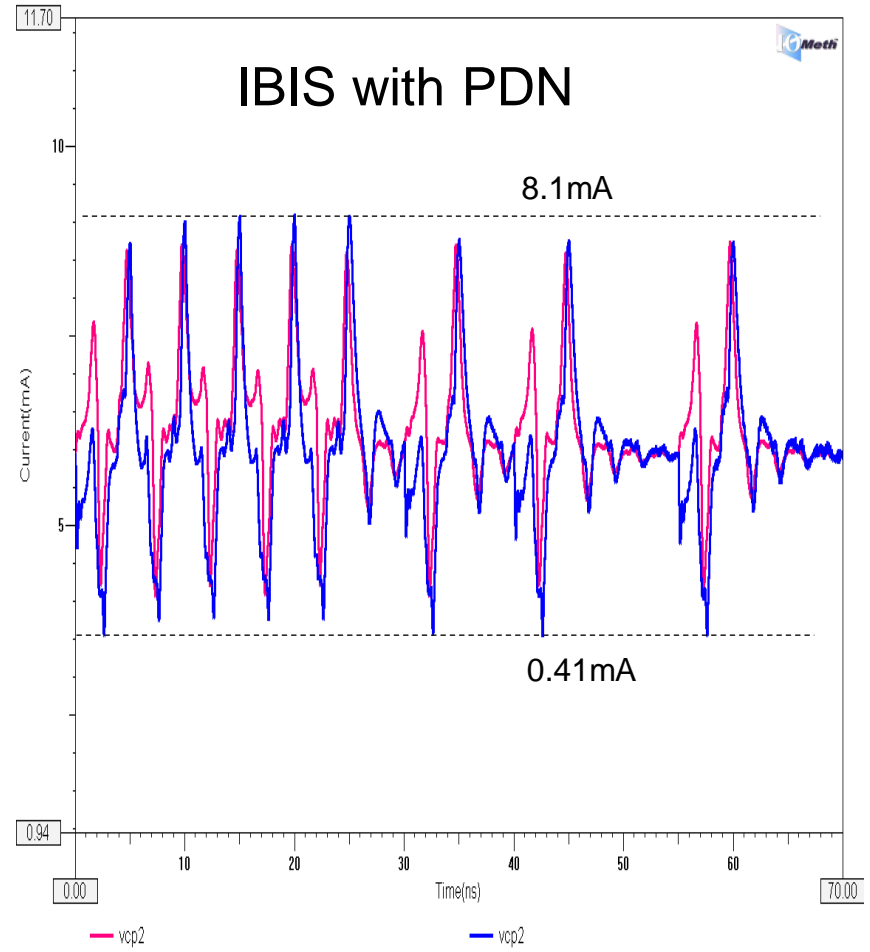
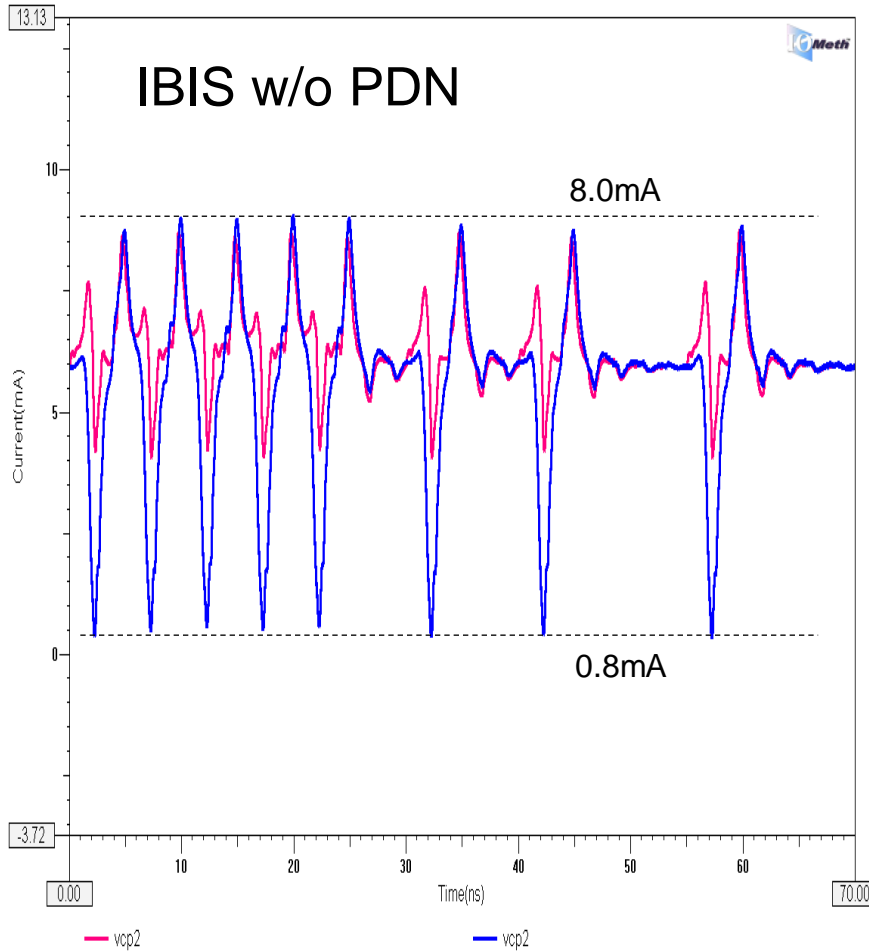

RED: Spice BLUE:IBIS

Summary

- IBIS PDN feature helps to have more accurate result for single-end buffer PDN simulation
- IBIS model without PDN features is not acceptable for differential pair PDN simulations
- If we can access to each P/N pin power source separately, the IBIS model with PDN feature can be used in differential pair PDN simulations accurately
- If we only can access to combined power source pins, the average-out method could be workaround to use in IBIS differential pair PDN simulations

The Modeling Specialist

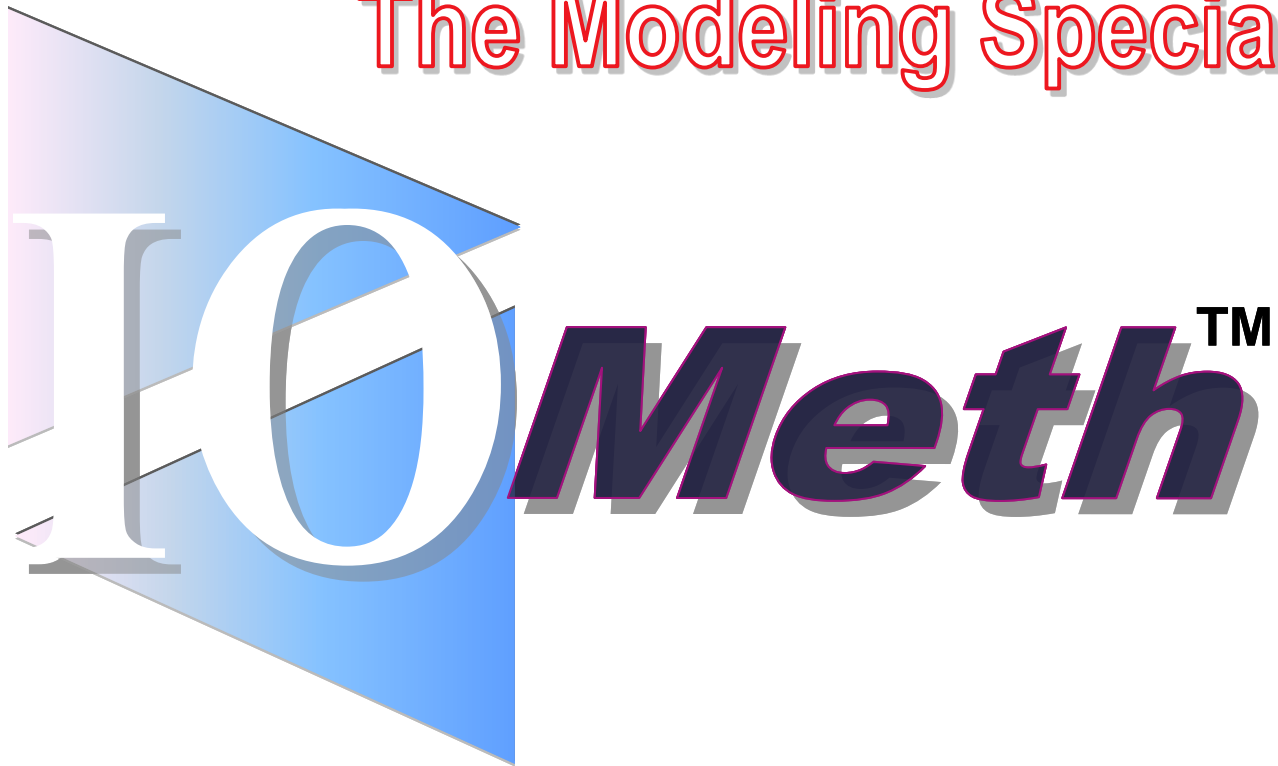

<http://www.iometh.com>