



IBIS AMI: Flows

Kumar Keshavan
Sigrity

Ambrish Varma
Cadence Design Systems



cādence™



SIGRITY



Objective

- Illustrate flows for the following cases
 - Tx_Init, Rx_Init
 - Tx_Init, Rx_Getwave
 - Tx_Getwave, Rx_Init
 - Tx_Getwave, Rx_Getwave
 - Wfm at rxpad, Rx_Init
 - Wfm at rxpad, Rx_Getwave

Tx_Init, Rx_Init only

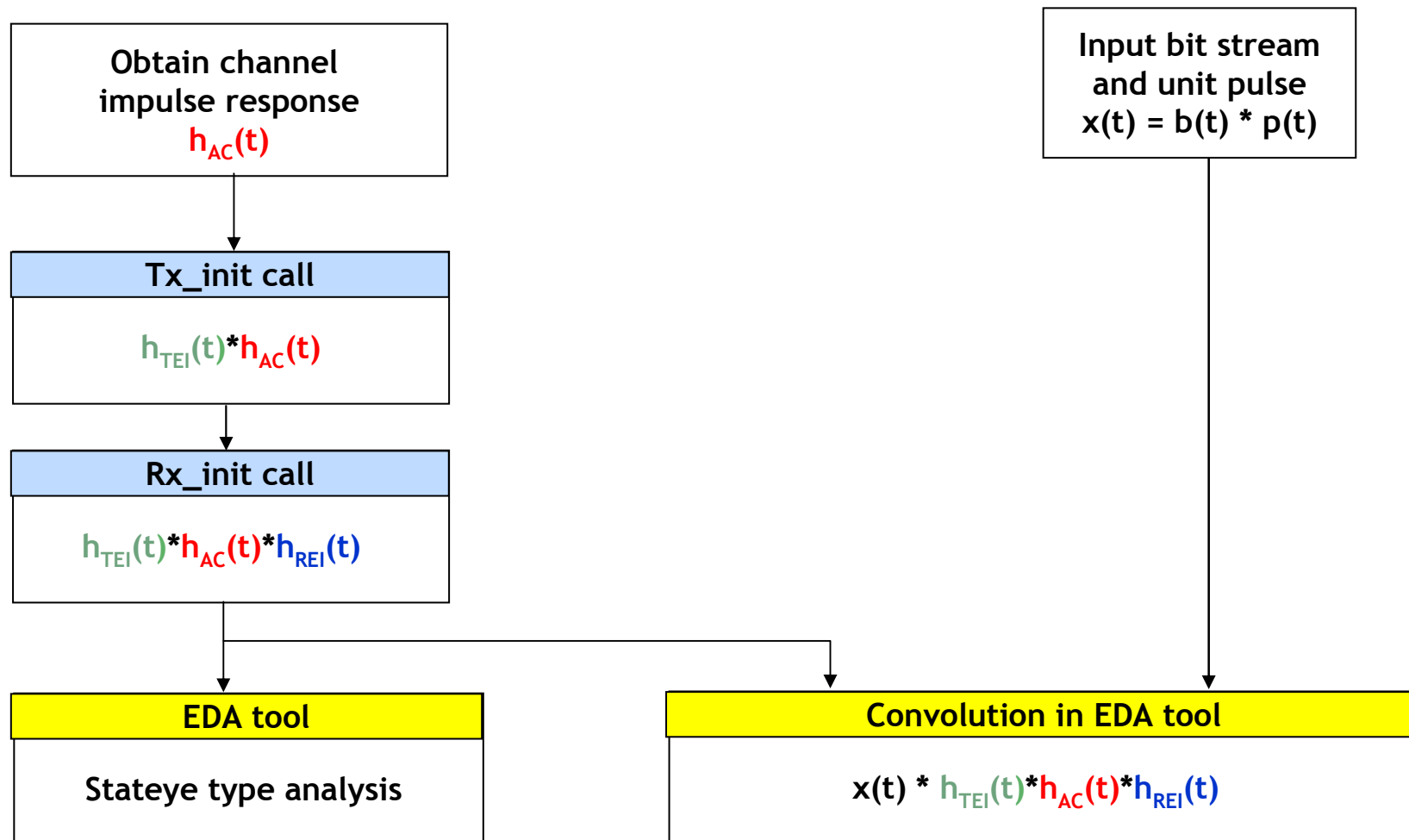

* = convolution



Tx_Init, Rx_Getwave

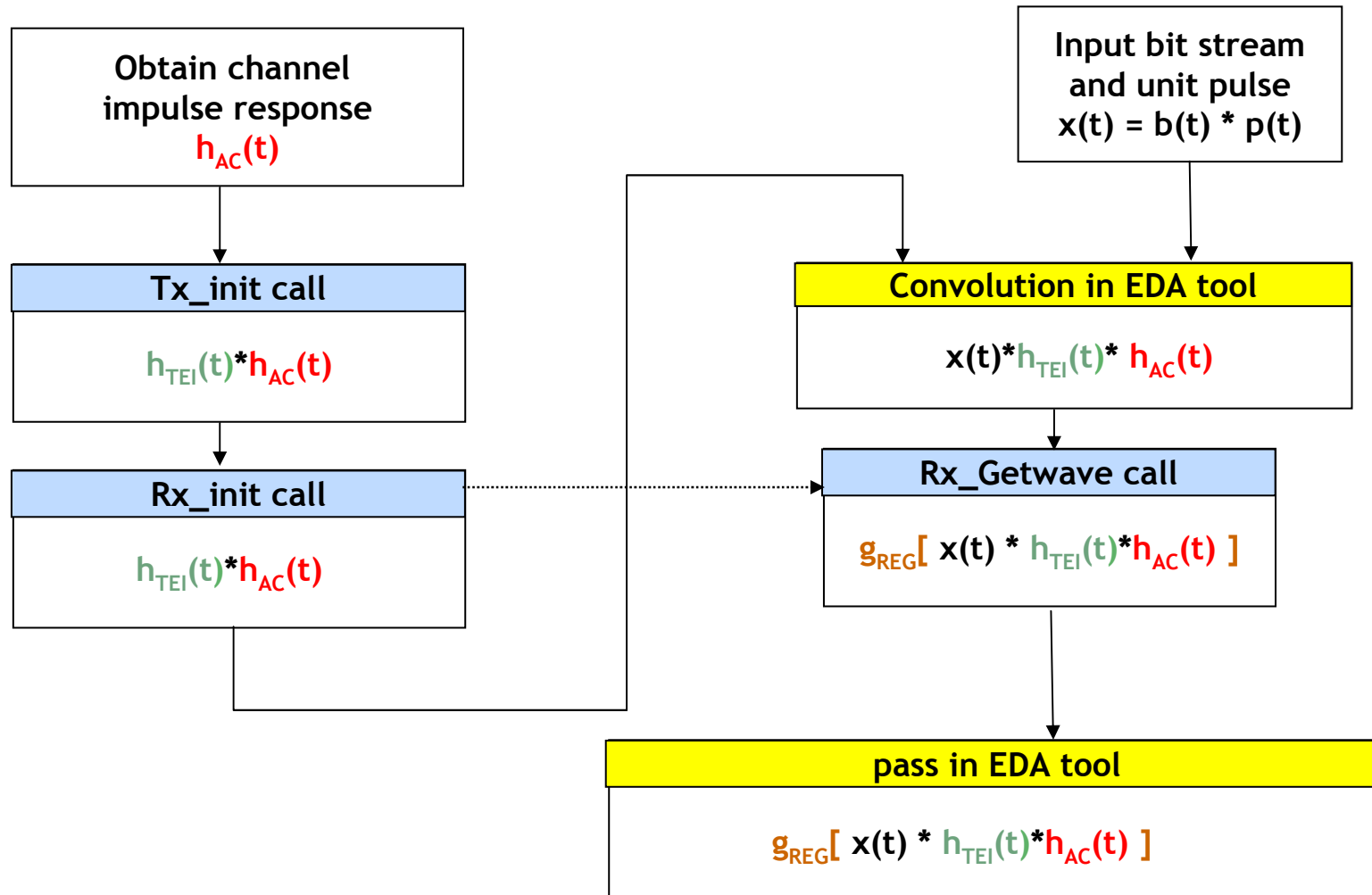

Tx_Getwave, Rx_Init

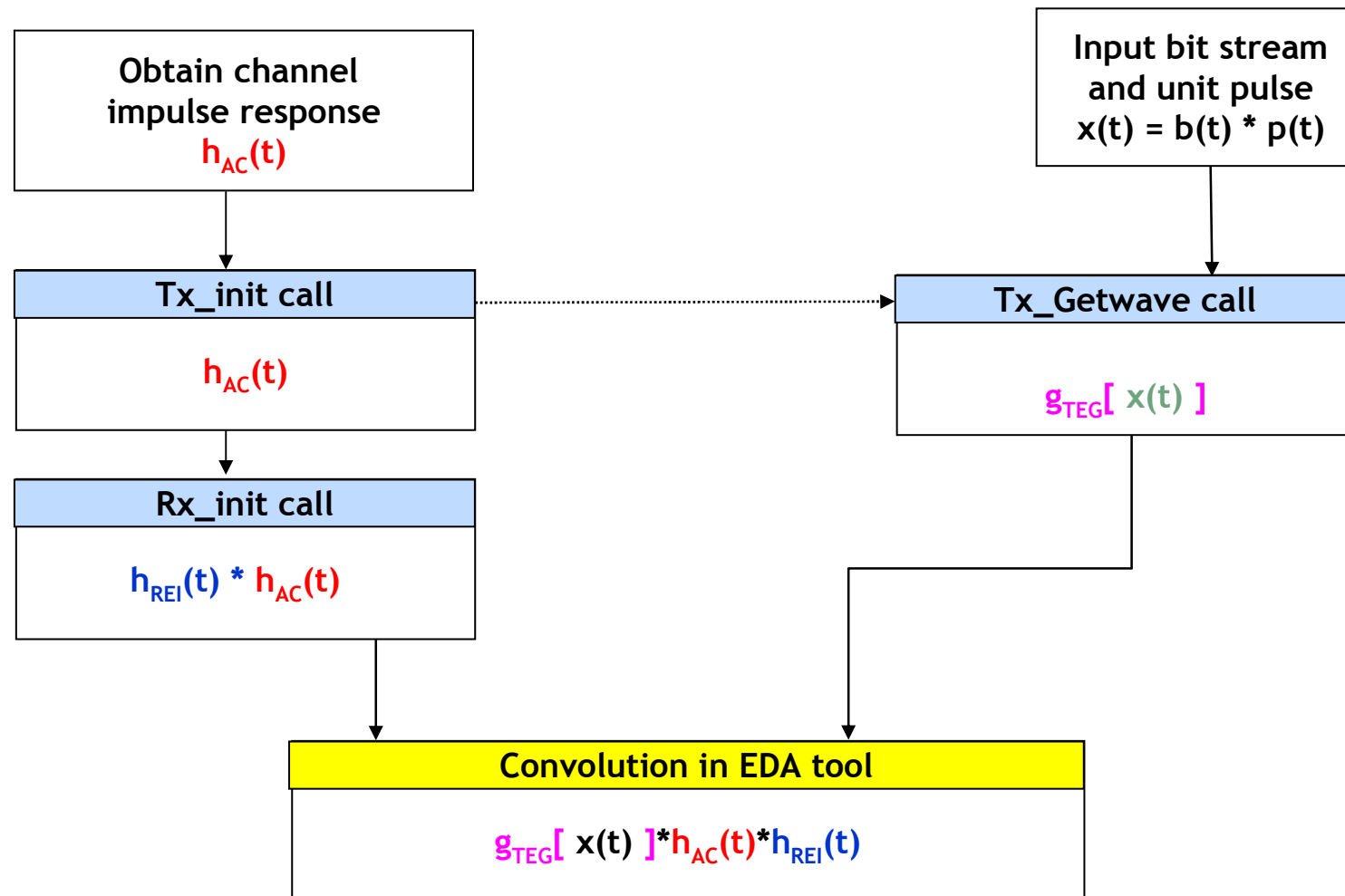



Tx_Getwave, Rx_Getwave

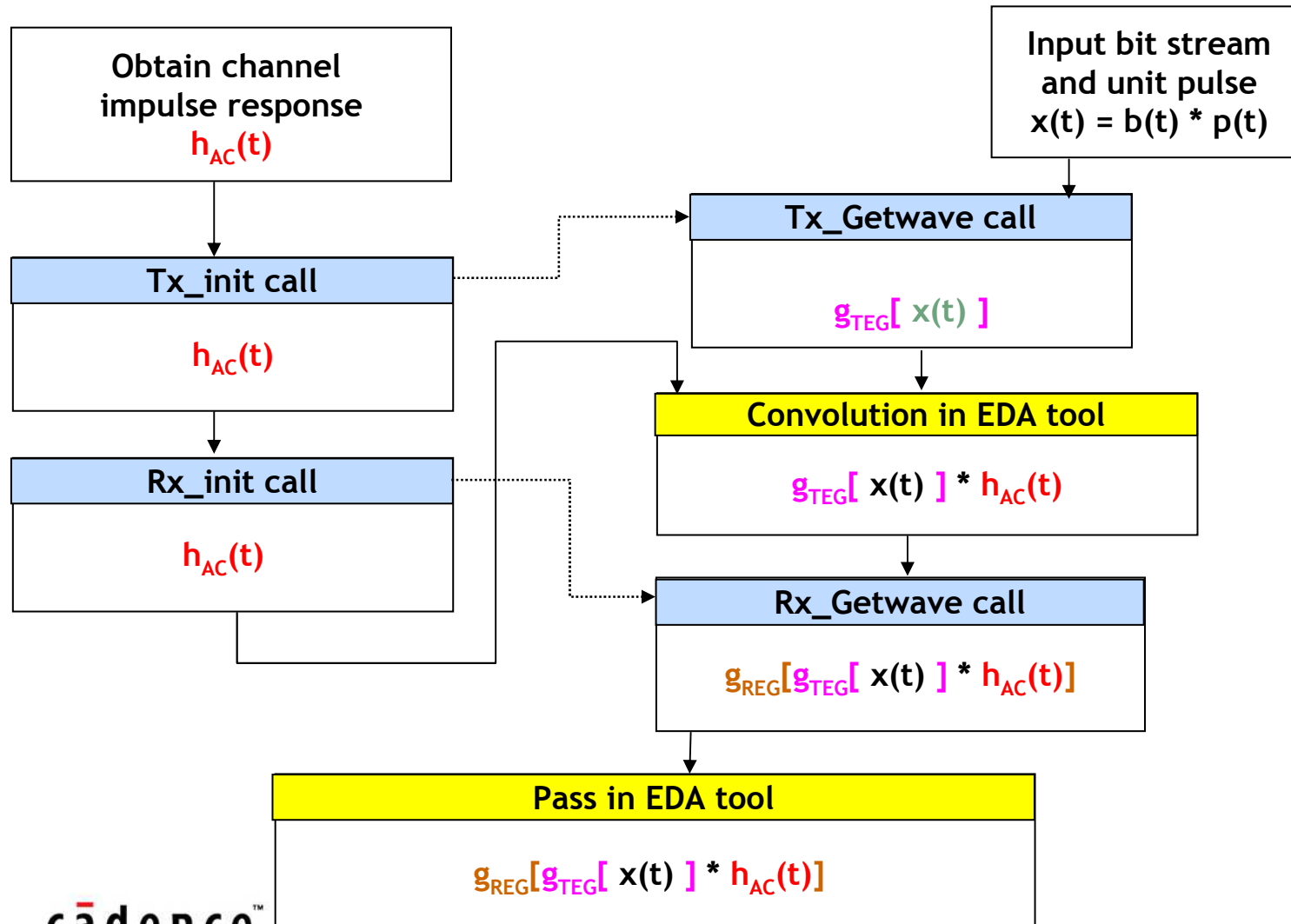



Rx_Init only, wfm at rx pad

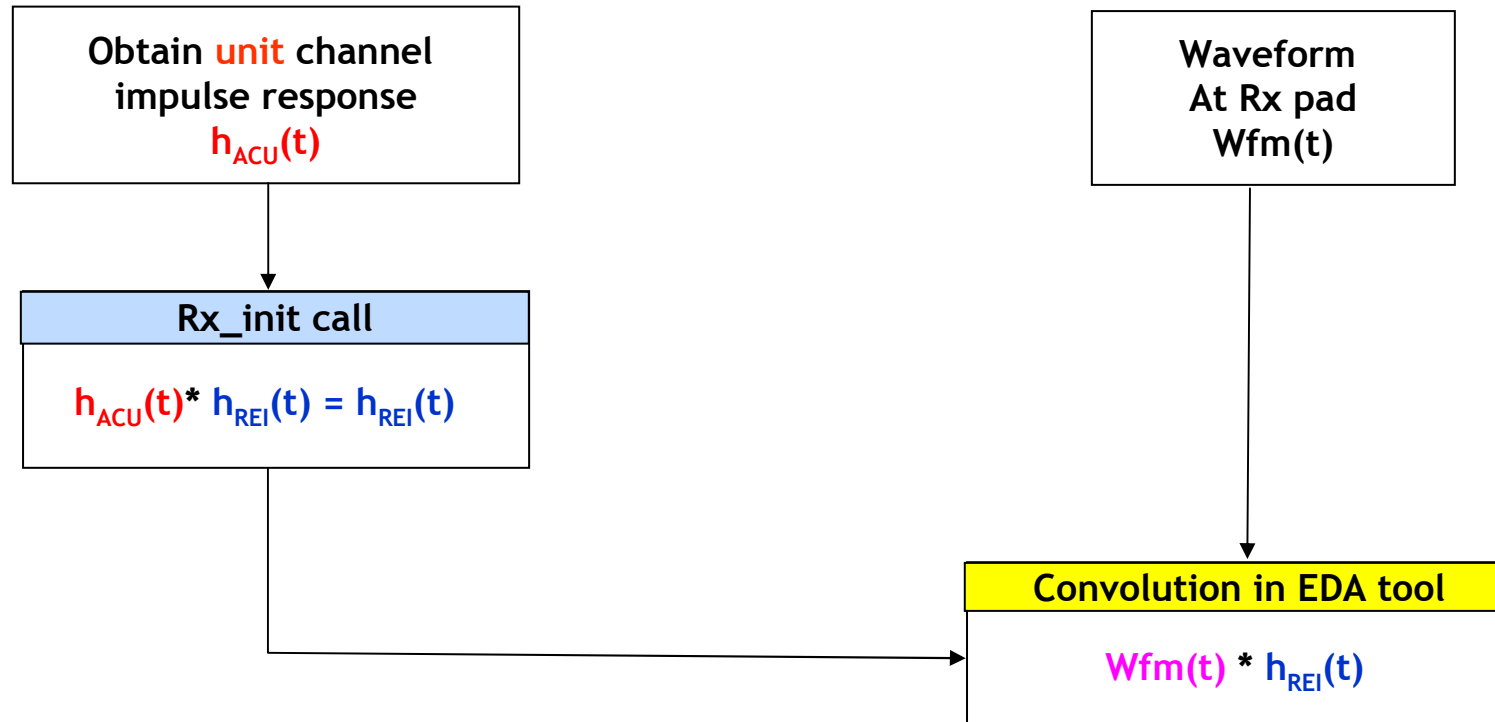

Rx_GetWave, Wfm at rx pad (no tx involvement)

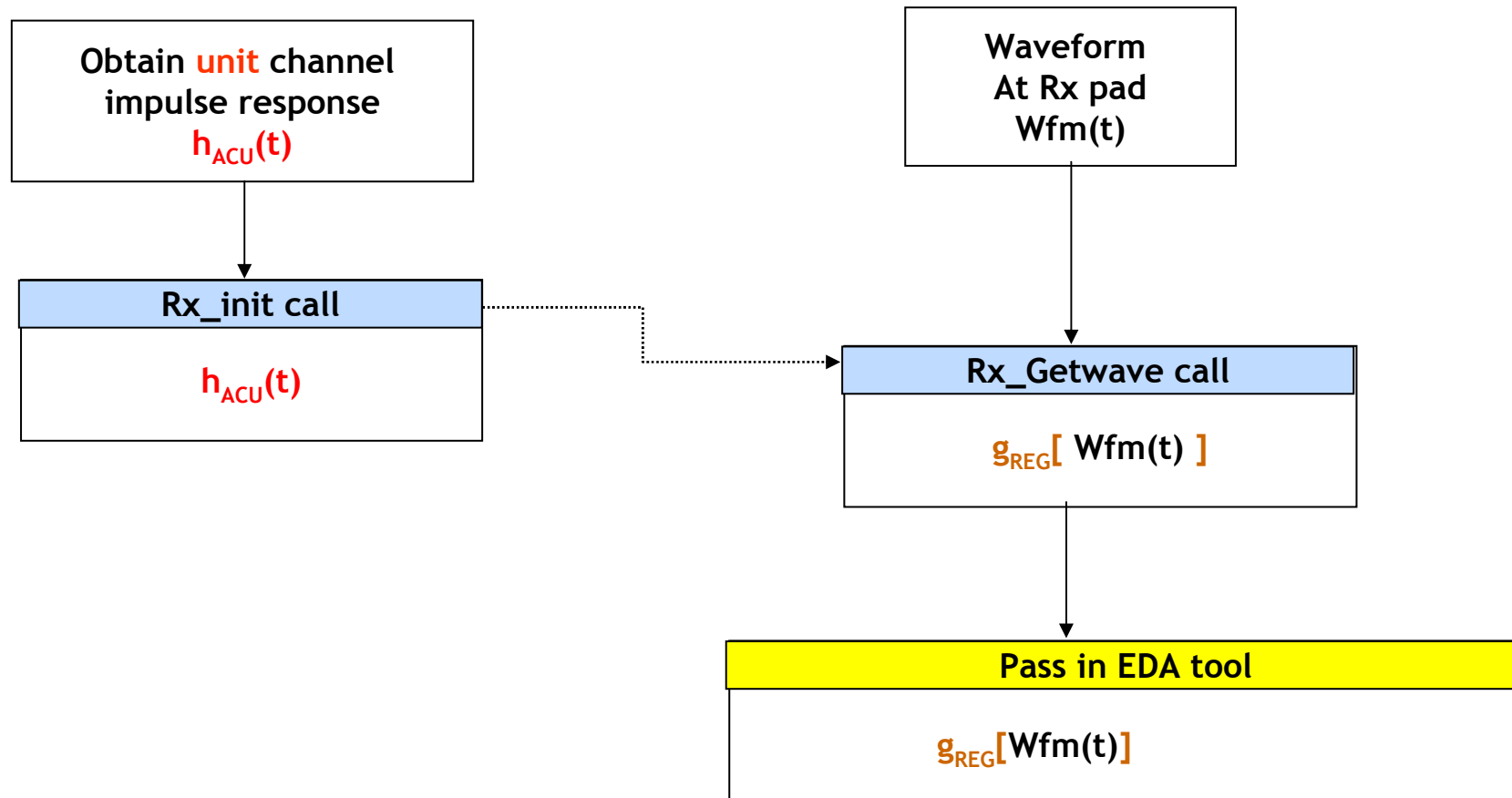

Summary

- Statistical analysis supported only in cases with no getwave call
- Time Domain simulation supported in all the cases
- The flow is simpler; there is no need for `init_returns_impulse` and `getwave_exists` parameters i.e. when `getwave` exists only time domain simulation is supported
- Models not supporting `getwave` simply will not have a `getwave`