More on IBIS Modeling for Load-Dependent Current- Mode Differential Drivers

Lance Wang (lwang@iometh.com)

IO Methodology Inc.

2013 IBIS Asian Summit

Nov. 15, 2013 Shanghai



Outlines

- Motivation
- Load-Dependent Current-Mode Differential Driver
- IBIS Extraction Method
 - Legacy method
 - Enhanced extraction method
- Summary

Note: The partial materials in this presentation have been presented in 2013 European IBIS Summit in Paris

Motivation

- Load-dependent current-mode differential pair buffers are found increasingly often in GHz serial link designs
 - Easy to control the output current and common-mode voltage
 - Often used in pre-emphasis buffers
- Using traditional IBIS buffer extraction method is not accurate enough

Is it possible to use the current IBIS spec for this kind of differential buffer?

Load-Dependent Current-Mode Differential Driver

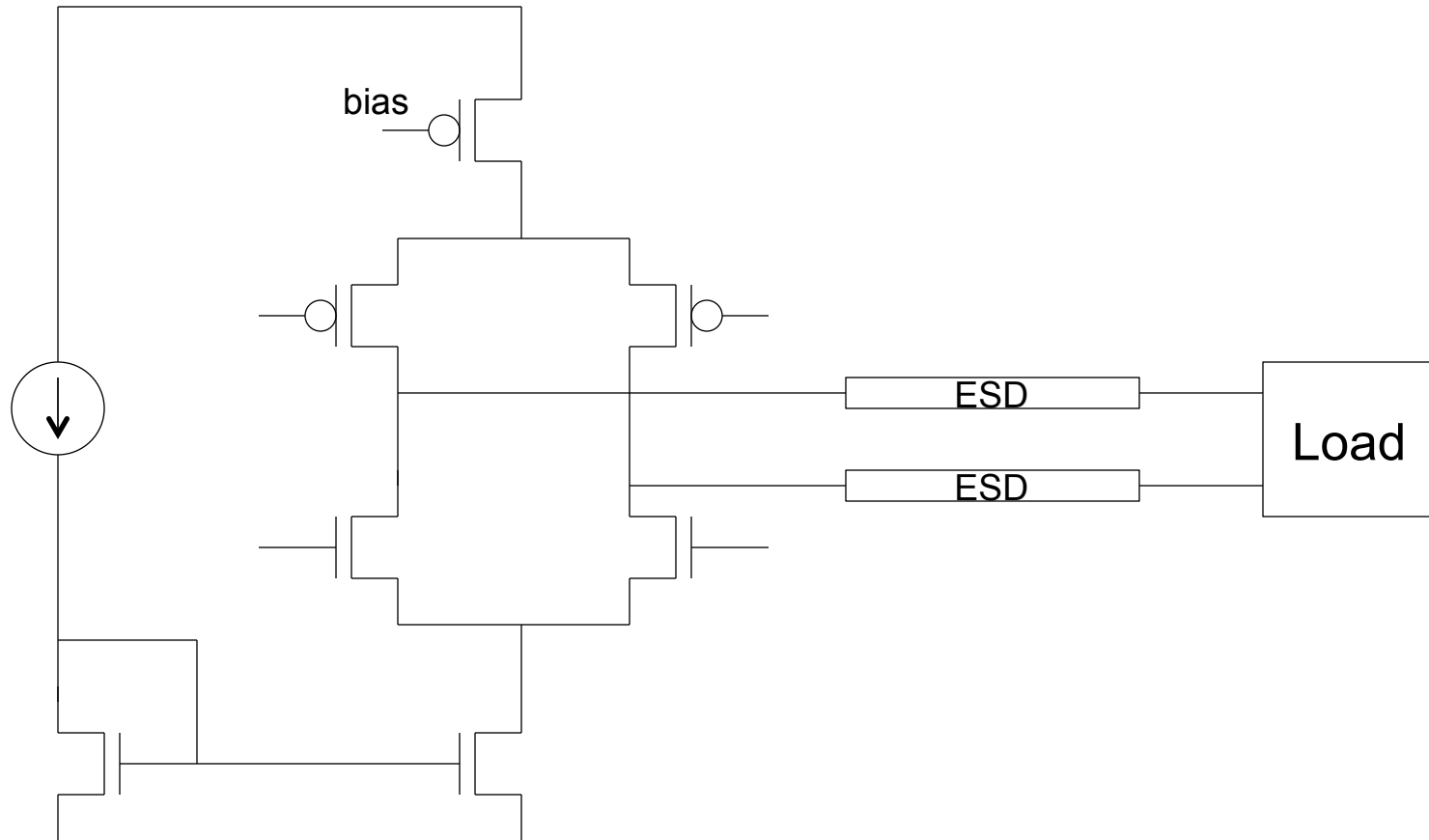

Load-Dependent Current-Mode Differential Driver (Current Flow)

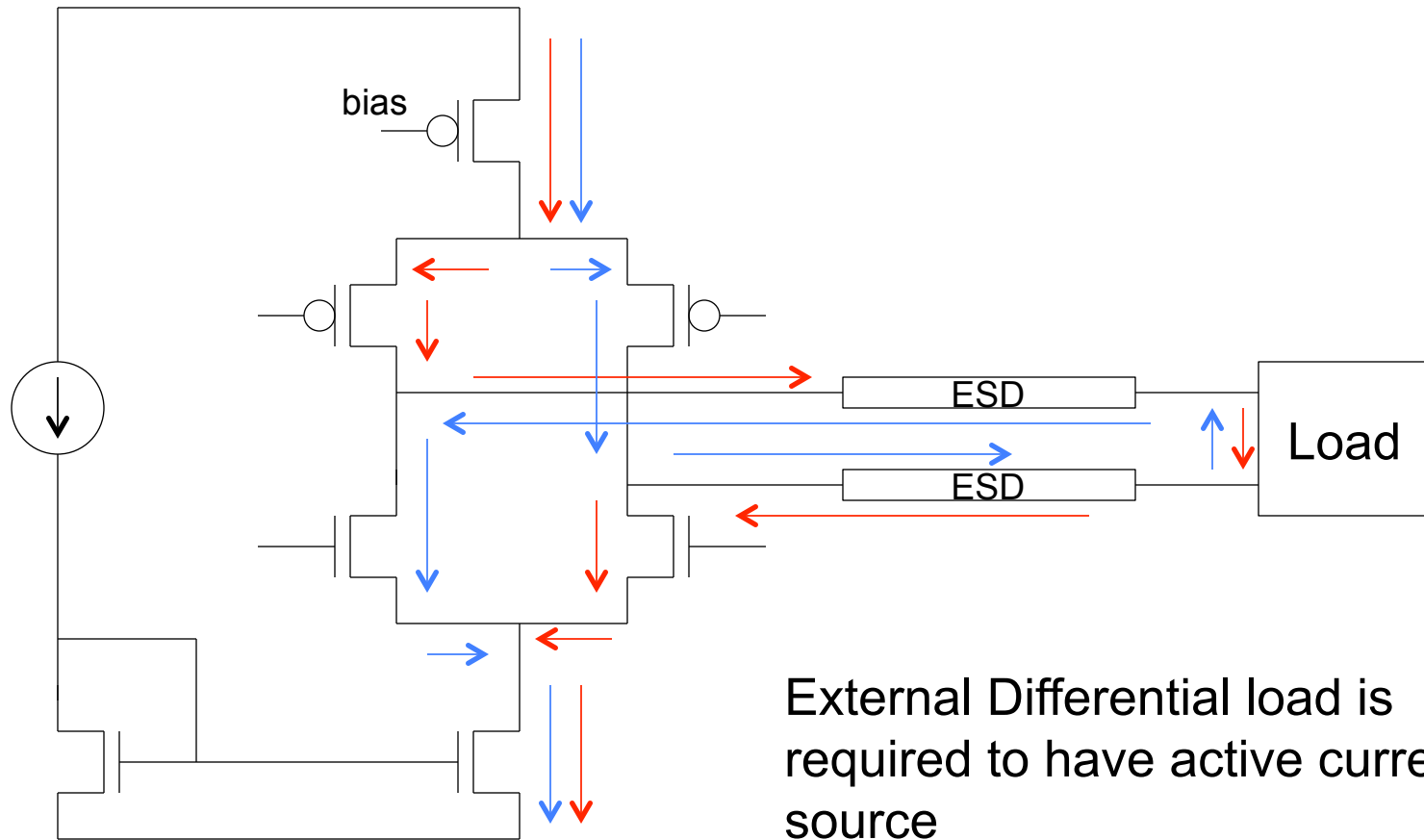

IBIS Extraction Method (Modeling as 2 individual pins)

No load to be used for I-V curve extraction

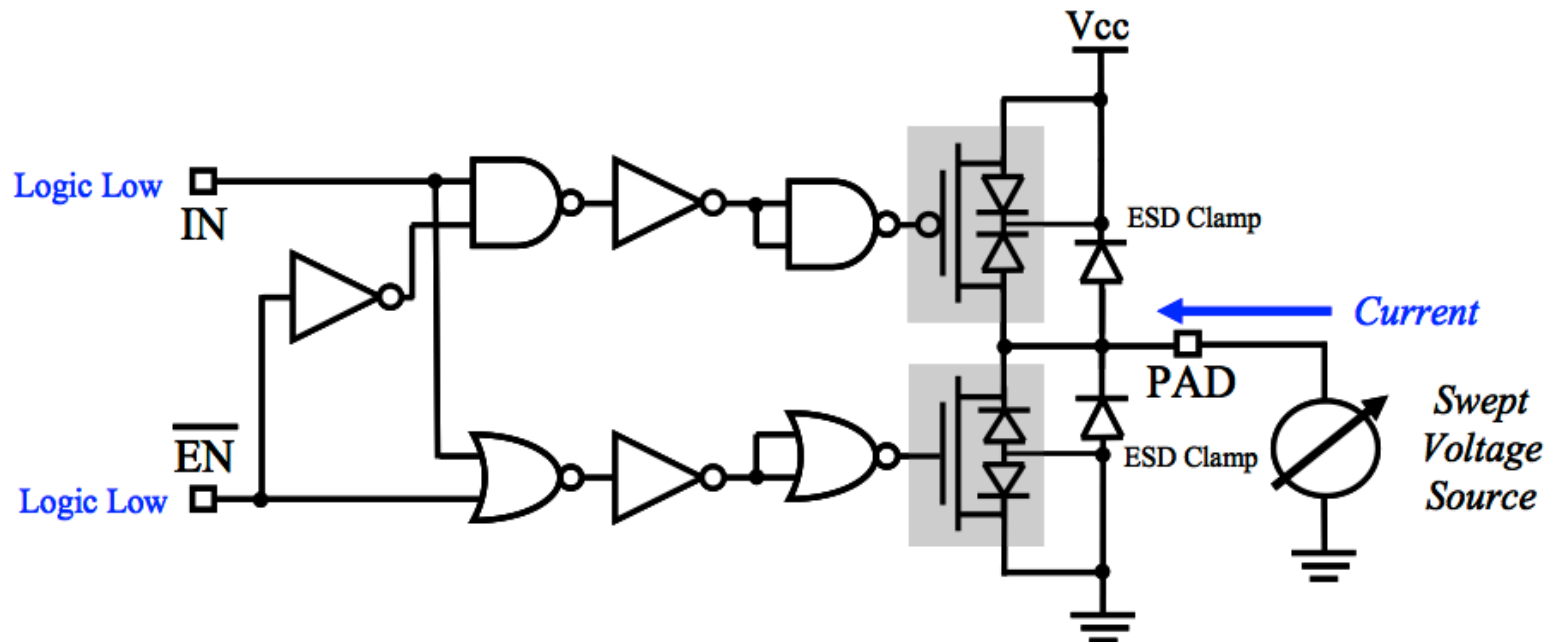

Figure 3.1 – Standard 3-state Buffer (Pulldown I-V Table Extraction Shown)

Pictures from IBIS cookbook

IBIS Extraction Method (Modeling as 2 individual pins)

Load connected to GND or VCC to be used for V-T curve extraction

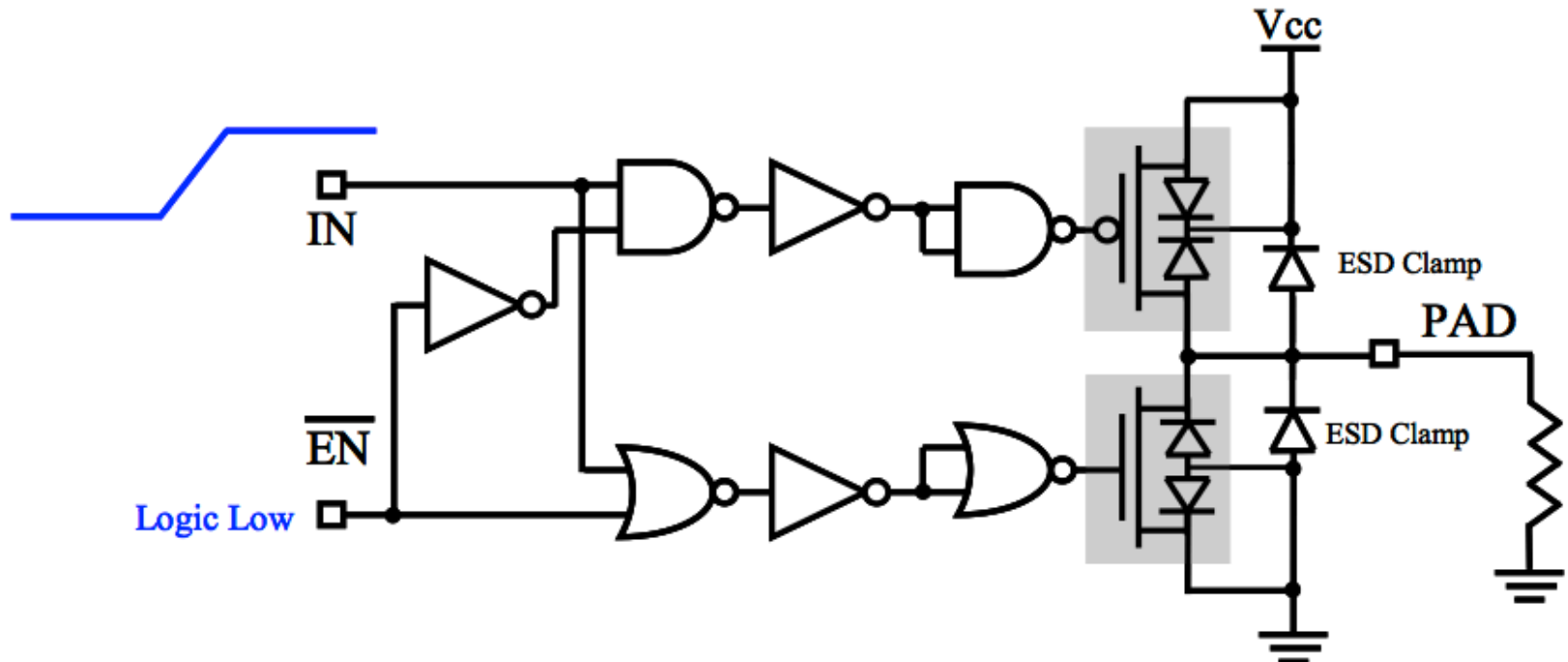
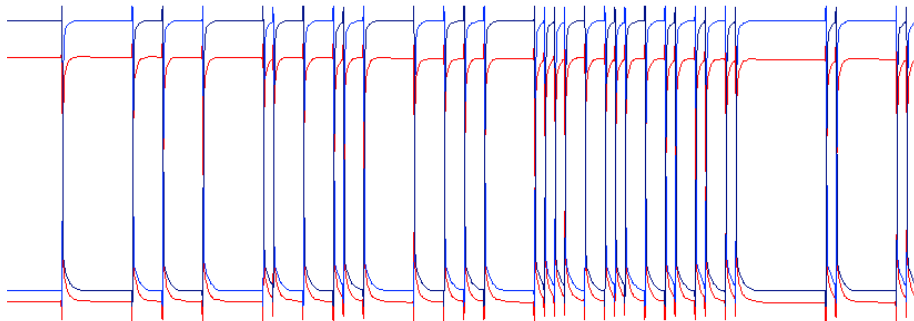
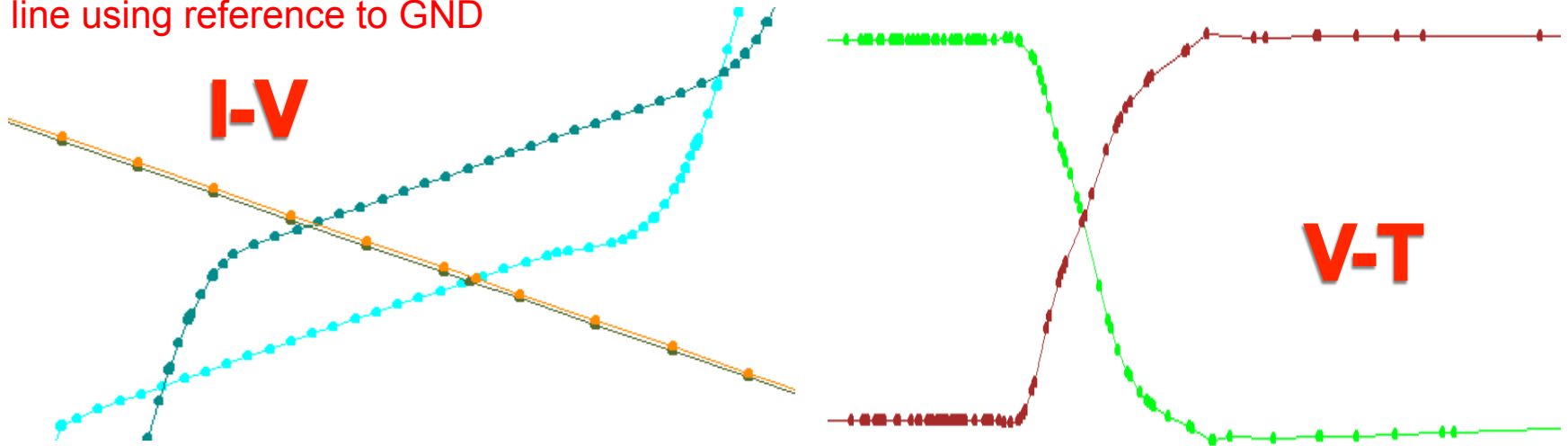

Figure 3.2 – Simulation Setup for Extracting Ramp Rate Information (Rising Edge Shown)

Pictures from IBIS cookbook

Using normal extraction methods for I-V and V-T curves

* I-V curves shown are combined curves and load line using reference to GND



Correlation shows they are way off from the Spice result
RED – Spice, **BLUE** - IBIS

Enhanced I-V Extraction Method

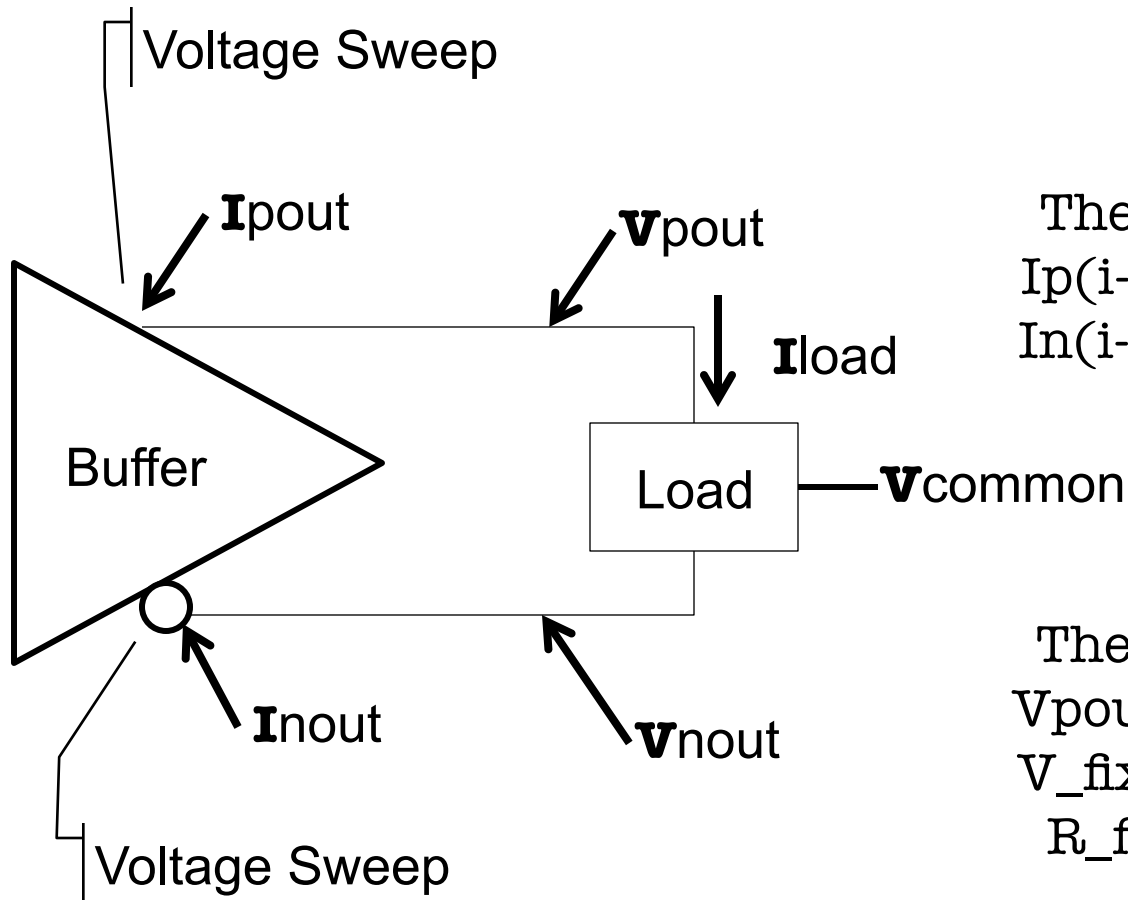

The IBIS I-V will be:
 $I_p(i-v) = I_{pout} - I_{load}$
 $I_n(i-v) = I_{inout} + I_{load}$

The IBIS V-T will be:
 V_{pout} and V_{nout} with
 $V_{fixture} = V_{common}$
 $R_{fixture} = R_{load}/2$

Using enhanced extraction method with differential load

* I-V curves shown are combined curves and load line using reference to GND

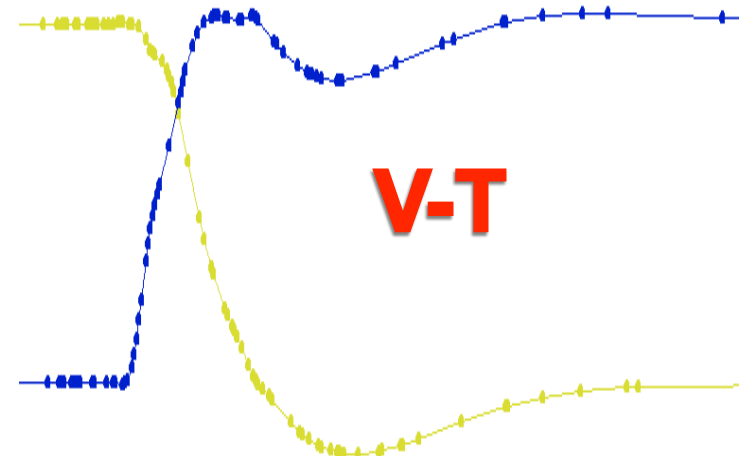
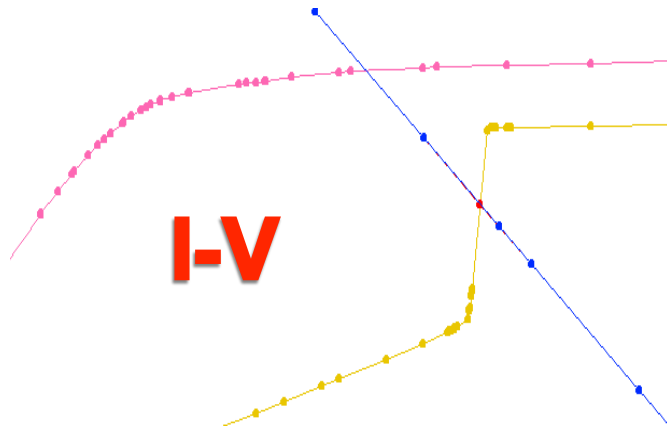

Correlation shows matched result with Spice

RED – SPICE, BLUE - IBIS

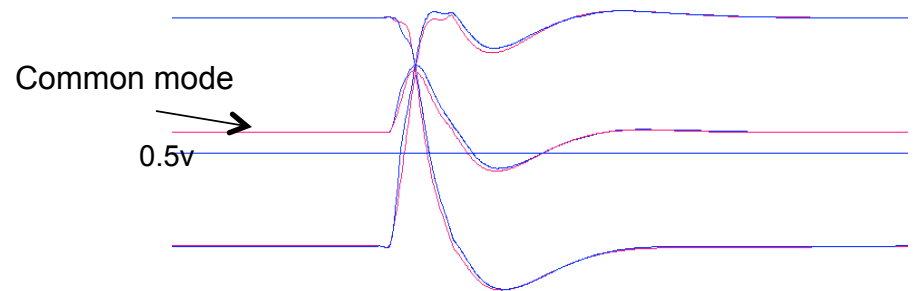

Summary

- Normal IBIS extraction method for load-dependent current-mode differential pair buffers produces inaccurate models
- Enhanced method considering differential load can solve this issue. It gives the matched results when correlating with Spice simulation results
- It would be better to have IBIS Spec accept “Rref_diff/Cref_diff” kind of differential loads for regular IBIS differential pair models
 - Rref_diff/Cref_diff is limited for External model use now
- IBIS Spec needs to be enhanced when modeling dynamic PLL current mode buffer
 - Various I-V tables for different diff_loads
 - Current dependent C-comp value table

The logo features the letters 'IO' in a large, white, 3D-style font with a blue shadow, set against a blue and purple gradient background. To the right, the word 'Meth' is written in a bold, italicized, dark blue font with a purple outline and a grey shadow. A small 'TM' trademark symbol is positioned above the end of 'Meth'.

IO MethTM

The Modeling Experts