

# Solving Receiver Electrical Test Challenges using IBIS AMI Modeling Techniques



Venkatesh Avula

IBIS Summit DAC 2014, San Francisco, CA

# Agenda

- **IBIS AMI Behavioral Buffer Model**
- **Receiver Test Challenges**
  - Ad-hoc Channels
  - Test Setup Complexity
  - Calibration Procedure
- **Proposed Solution and Results**
  - Model of Stress Signal Generator
  - Test Methodology
  - Correlation

# Agenda

## IBIS AMI Behavioral Buffer Model

### Receiver Test Challenges

- Ad-hoc Channels
- Test Setup Complexity
- Calibration Procedure

### Proposed Solution and Results

- Model of Stress Signal Generator
- Test Methodology
- Correlation

# IBIS AMI Behavioral Buffer Model

- How to ascertain a transmitted signal without probing it?

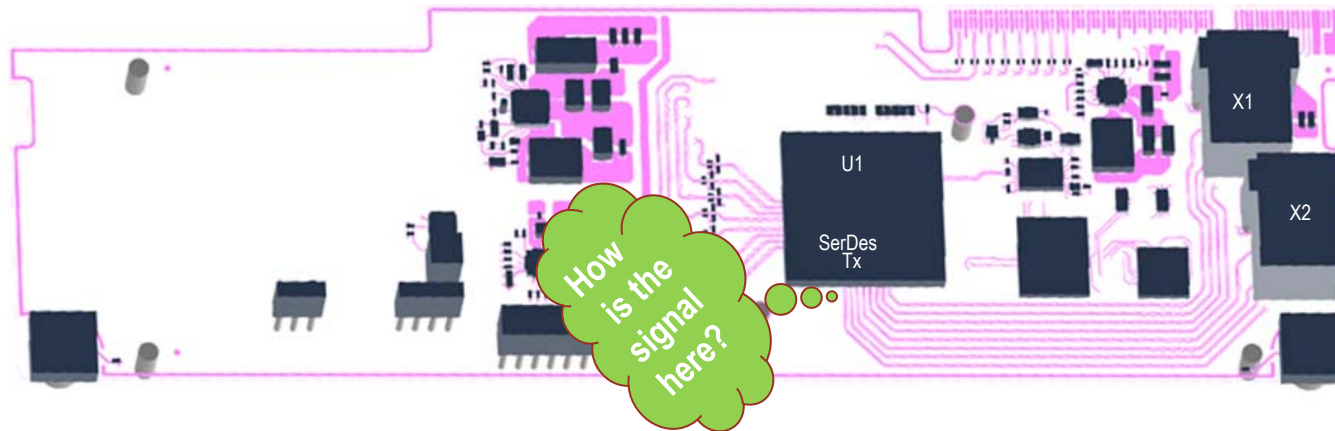

- IBIS AMI model of the SerDes IC comes to the rescue.
- It emulates the buffer's periphery analog frontend circuit as well as the internal signal processing elements like Equalizer.

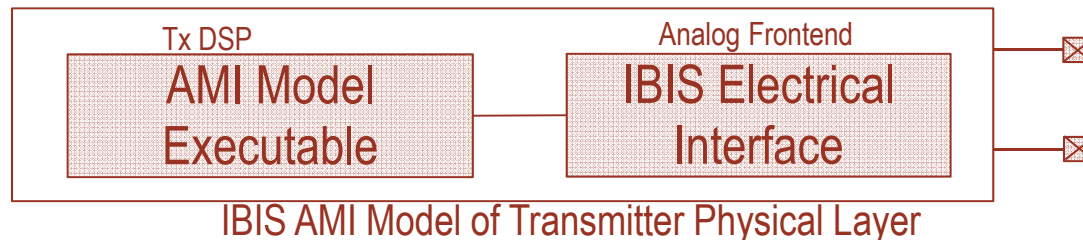

# Agenda

## IBIS AMI Behavioral Buffer Model

### Receiver Test Challenges

- Ad-hoc Channels
- Test Setup Complexity
- Calibration Procedure

### Proposed Solution and Results

- Model of Stress Signal Generator
- Test Methodology
- Correlation

# Ad-hoc Channels

- The buzz applications like cloud computing are driving the following channel requirements in serial links-
  - Non-standard form factor connector. Ex: PCIe over MiniSAS HD cable
  - Multi-board design. Ex: orthogonal mid-plane or cabled backplane architecture
  - Retimer based. Ex: long-reach 4x25G connections for network backplane
- Such ad hoc channels introduce new challenges into the already-complex receiver test procedure for design and validation engineers.

# Rx Test Setup Complexity

- Receiver need to be tested with the worst case signals.
- Serial standards specify the worst case impairments at Rx. Multiple test instruments are usually required to generate such signals.
- PCIe 2.0 example:

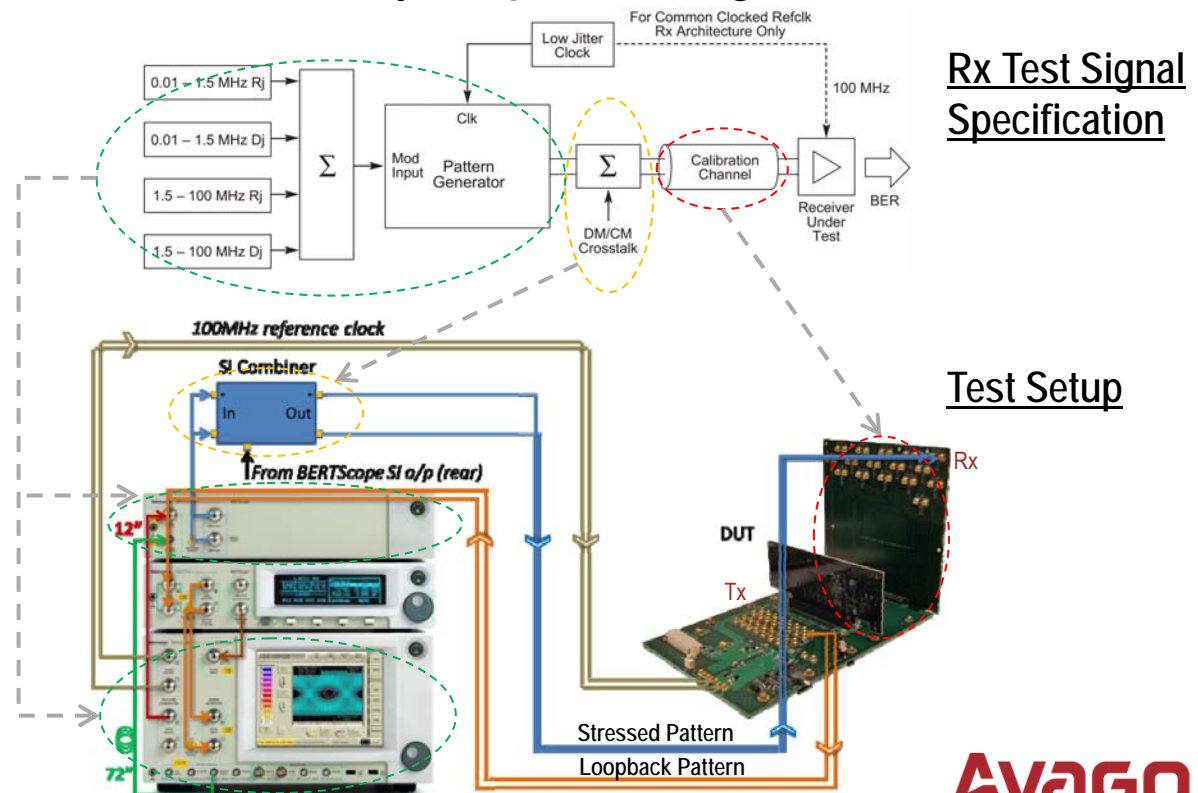

# Calibration Procedure

- Calibration is time consuming process.
- Oscilloscope measures the amount of impairments. Scope and stress signal generator work in closed loop fashion to set the cocktail of impairments in the signal to the right mix as per the spec.
- Not only each impairment need to be calibrated independently but also the combined signal's eye diagram shall hug the TP2 eye mask.

# Agenda

## IBIS AMI Behavioral Buffer Model

### Receiver Test Challenges

- Ad-hoc Channels
- Test Setup Complexity
- Calibration Procedure

### Proposed Solution and Results

- Model of Stress Signal Generator
- Test Methodology
- Correlation

# Proposed Model of Stress Signal Generator

- An IBIS AMI model of stress signal generator is proposed to solve the aforementioned unwieldy Rx test challenges.

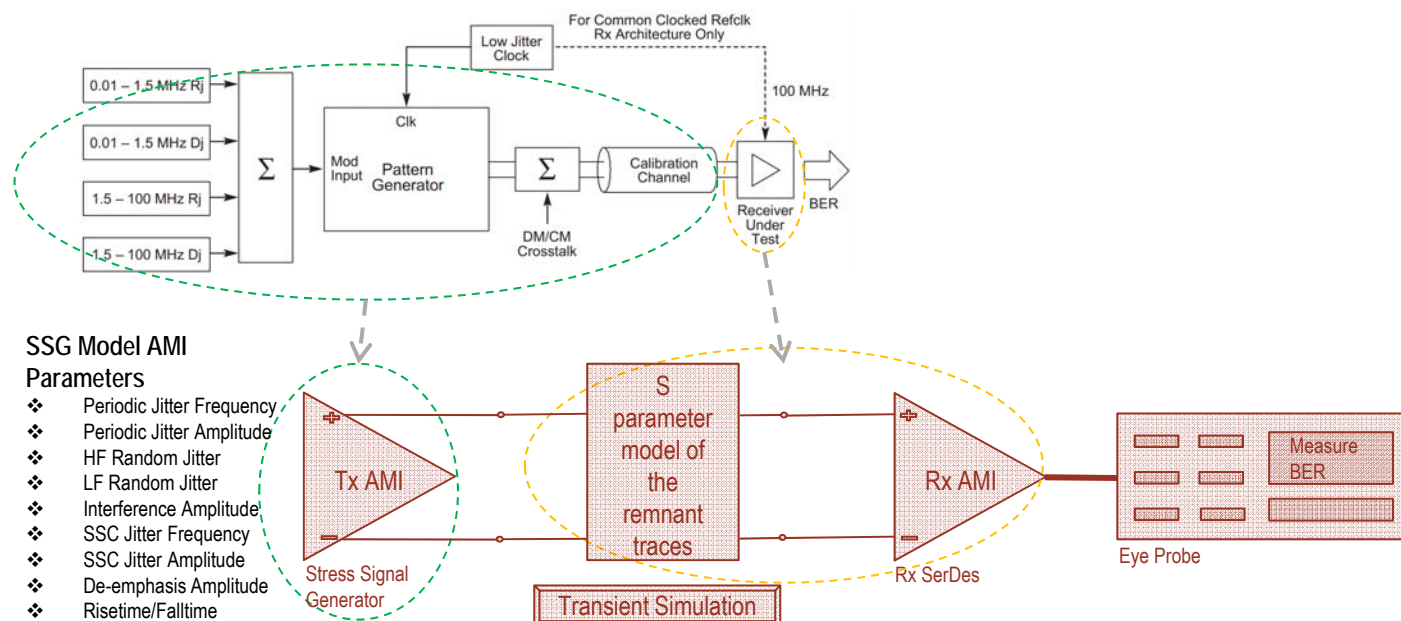

- Thus the concept of IBIS AMI modeling is extended from simulating the behavioral aspects at IC level to system level stress signal generators used for Rx testing.

# Proposed Rx Test Methodology

## • Calibration

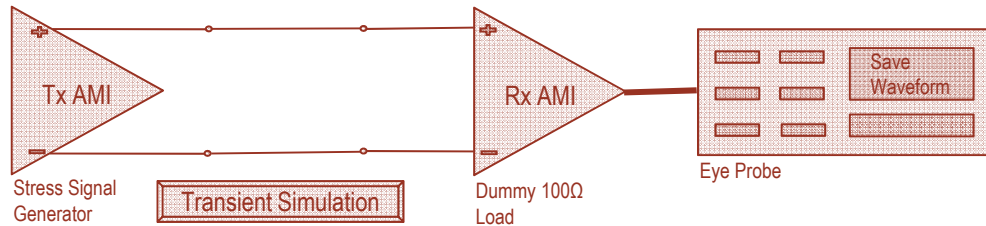

### Process

- ✓ Dummy load receives the signals unobtrusively
- ✓ Eyescope saves the waveforms
- ✓ Measurement software like SigTest processes the waveform files and gives the results
- ✓ Adjust the parameters of the Stress Signal Generator model if the measured result values are not confirming to the standard specification

## • Test Procedure

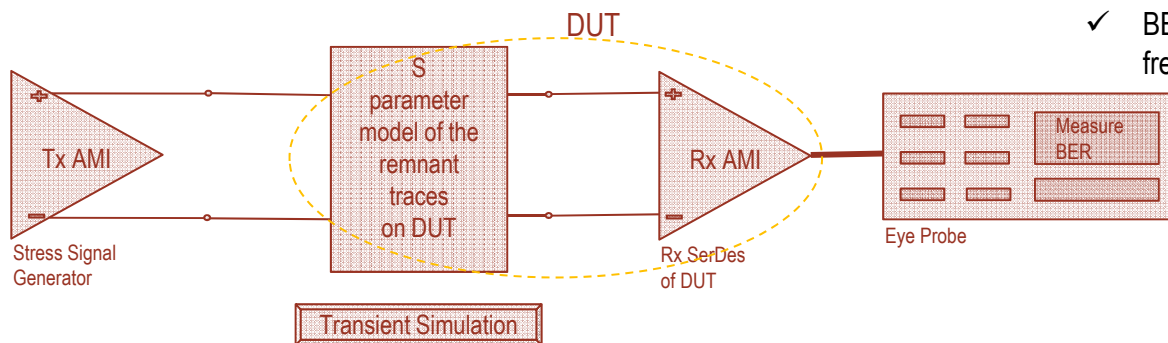

### Process

- ✓ Calibrated parameters are set for the SSG model
- ✓ BER is measured by sweeping the sinusoidal jitter frequency and amplitude across the tolerance curve

# Correlation

- For a PCIe add-in card DUT operating at 5Gbps data rate, close correlation between the BERT based receiver test method and the IBIS AMI method is seen.

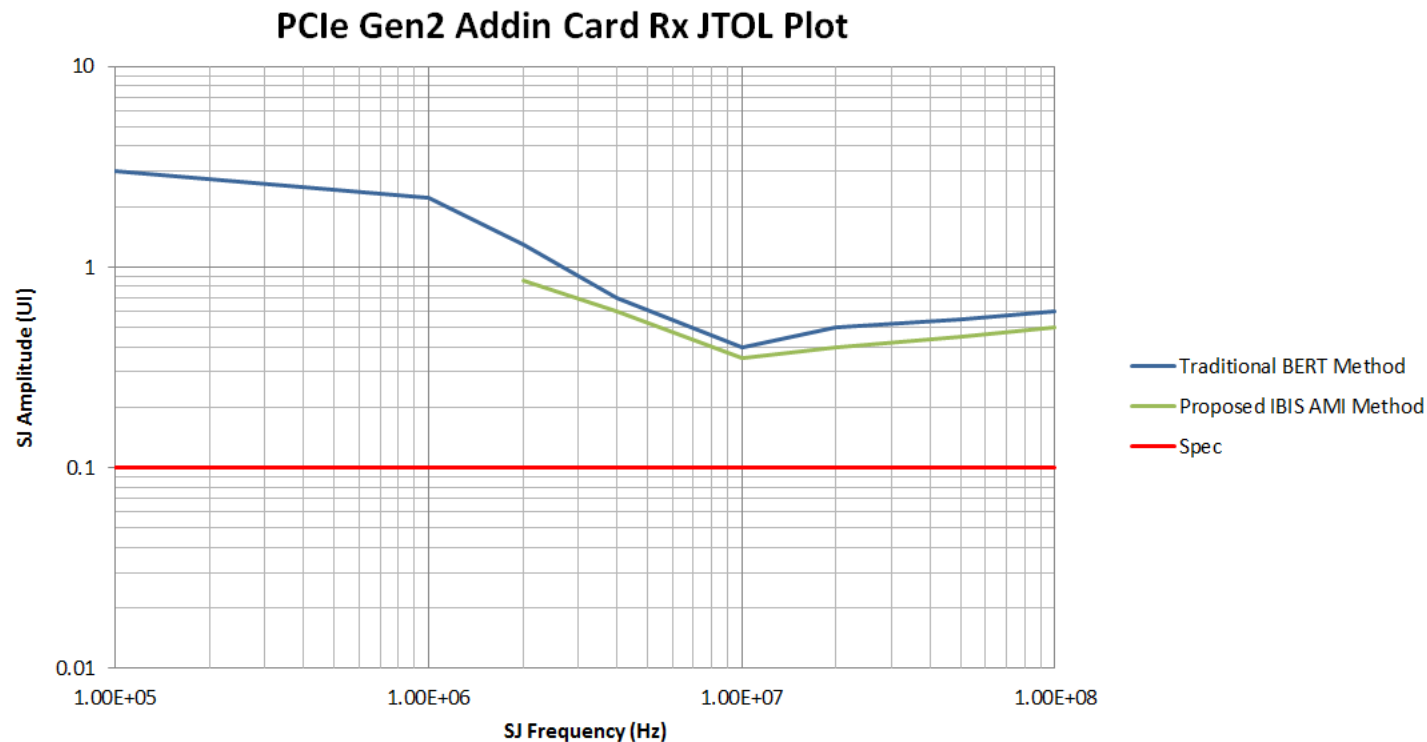

# Conclusion

- The proposed IBIS AMI model of Stress Signal Generator helps in solving the Rx test challenges.
- Insight can be gained into the DUT's jitter tolerance performance with the proposed method.
- The accuracy of the proposed method hinges on the correlation of Rx IBIS AMI models to the actual Rx SerDes IC over the PVT corners.

# References

- PCI Express Base Specification Revision 2.1
- "PCI Express 5.0 GT/s Add-In Card Receiver CEM Testing", Tektronix MOI, SR-TN080
- IBIS AMI Specification 5.1